



Omnivision VHS

Panasonic

Video Cassette Recorder Operating Instructions

Model No. **PV-V4620**

Basic Operation

Advanced Operation

For Your Information

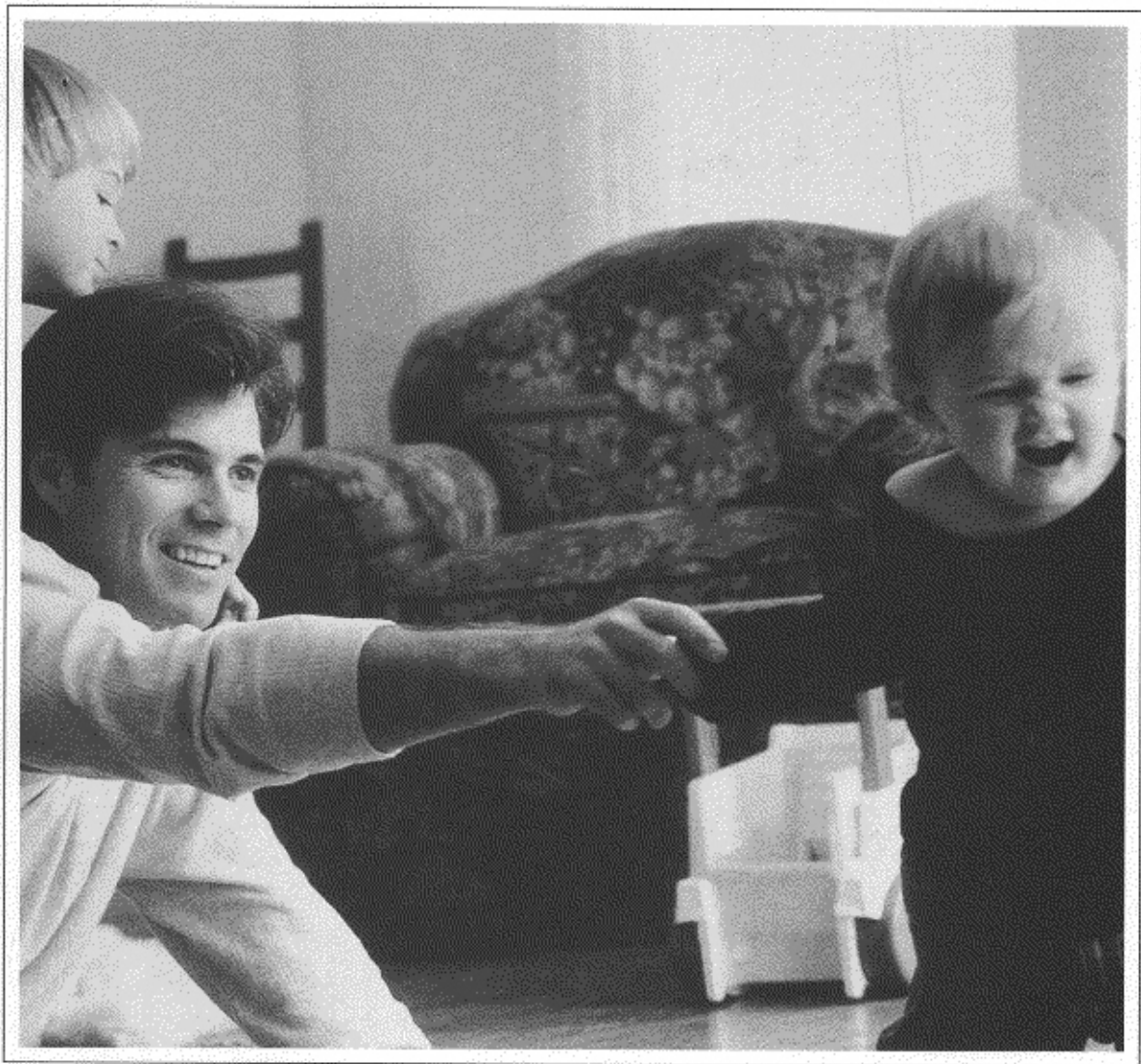

Please read these instructions carefully before attempting to connect, operate or adjust this product. Please save this manual.

Spanish Quick Use Guide is included. (Guía para rápida consulta en español está incluida.)

Quick Use Guide is on the back cover.

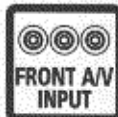

As an ENERGY STAR® Partner, Matsushita Electric Corporation of America has determined that this product or product model meets the ENERGY STAR® guidelines for energy efficiency.



LSQT0193A

For assistance, call 1-800-211-PANA(7262).

Important Safeguards and Precautions

FOR YOUR SAFETY, READ AND RETAIN ALL SAFETY AND OPERATING INSTRUCTIONS. HEED ALL WARNINGS IN THE MANUAL AND ON THE UNIT

INSTALLATION

1 POWER SOURCE CAUTION

Operate only from a power source indicated on the unit or in this manual. If necessary, have your Electric Utility Service Company or Video Products Dealer verify the power source in your home.

2 POLARIZED OR GROUNDING PLUG

As a safety feature, this Video product comes with either a polarized power cord plug (one blade is wider than the other), or a three-wire grounding type plug.

POLARIZED PLUG CAUTION:

This plug will only fit into an outlet one way. If you cannot fully insert the plug, try reversing it. If it still will not fit, have an electrician install the proper wall outlet. Do not defeat the safety feature by tampering with the plug.

GROUNDING PLUG CAUTION:

This plug will only fit into a three-hole grounding outlet. If necessary, have an electrician install the proper outlet. Do not defeat the safety feature by tampering with the plug.

3 POWER CORD

Make sure power cords are routed so that they are not likely to have anything rest on them, roll over them, or be in the way of walking traffic. If an extension cord is used, make sure it also has either a polarized or grounded plug and that the cords can be securely connected. Frayed cords, damaged plugs, and damaged or cracked wire insulation are hazardous and should be replaced by a qualified service technician. Overloaded outlets and extension cords are fire hazards and should be avoided.

4 DO NOT BLOCK VENTILATION HOLES

Ventilation openings in the cabinet release heat generated during operation. If they are blocked, heat build-up inside the unit can cause failures that may result in a fire hazard or heat damage to cassettes.

For protection, follow these rules:

- Never cover ventilation slots or the unit while in use, or operate the unit when placed on a bed, sofa, rug, or other soft surface.
- Avoid built-in installation, such as a book case or rack, unless proper ventilation is provided.

5 AVOID EXTREMELY HOT LOCATIONS OR SUDDEN TEMPERATURE CHANGES

Do not place the unit over or near any kind of heater or regulator, in direct sunlight, inside a closed vehicle, etc.. Do not move the unit suddenly between areas of extreme temperature variation. If the unit is suddenly moved from a cold place to a warm place, moisture may condense in the unit and on the tape.

6 TO AVOID PERSONAL INJURY

- Do not place unsecured equipment on a sloping surface.
- Do not place this unit on any support that is not firm, level, and adequately strong. The unit could fall causing serious injury to a child or adult and damage to the unit.
- An appliance and cart combination should be moved with care. Quick stops, excessive force, and uneven surfaces may cause the appliance and cart combination to overturn.
- Carefully follow all operating instructions and use the manufacturer's recommended accessories when operating this unit or connecting it to any other equipment.



Safety Precautions

Warning: To prevent fire or shock hazard, do not expose this equipment to rain or moisture.

CAUTION: To prevent electric shock, match wide blade of plug to wide slot, fully insert.

Attention: Pour éviter les chocs électriques, introduire la lame la plus large de la fiche dans la borne correspondante de la prise et pousser jusqu'au fond.



This symbol warns the user that uninsulated voltage within the unit may have sufficient magnitude to cause electric shock. Therefore, it is dangerous to make any kind of contact with any inside part of this unit.



This symbol alerts the user that important literature concerning the operation and maintenance of this unit has been included. Therefore, it should be read carefully in order to avoid any problems.

OUTDOOR ANTENNA INSTALLATION

1 SAFE ANTENNA AND CABLE CONNECTION

If an outside antenna or cable system is connected to the equipment, be sure the antenna or cable system is grounded so as to provide some protection against built up static charges and voltage surges.

Section 810 of the National Electrical Code, ANSI/NFPA 70 (in Canada, part 1 of the Canadian Electrical Code) provides information with respect to proper grounding of the mast and supporting structure, grounding of the lead-in wire to an antenna discharge unit, size of grounding conductors, location of antenna discharge unit, connection to grounding electrodes and requirements for the grounding electrode.

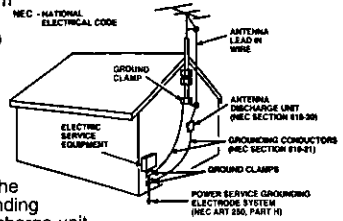

2 KEEP ANTENNA CLEAR OF HIGH VOLTAGE POWER LINES OR CIRCUITS

An outside antenna system should be located well away from power lines, electric light or power circuits and where it will never come into contact with these power sources if it should happen to fall. When installing an outside antenna, extreme care should be taken to avoid touching power lines, circuits or other power sources as this could be fatal. Because of the hazards involved, antenna installation should be left to a professional.

USING THE VIDEO UNIT

If the unit has been in storage or moved to a new location, refer first to the INSTALLATION section of these safeguards.

1 REFER THIS VIDEO UNIT AWAY FROM WATER OR MOISTURE OF ANY KIND.

2 **IF EQUIPMENT IS EXPOSED TO RAIN, MOISTURE, OR STRONG IMPACT,** unplug the unit and have it inspected by a qualified service technician before use.

3 DURING AN ELECTRICAL STORM

During a lightning storm, whether indoors or outdoors, or before leaving the unit unused for extended periods of time, disconnect all equipment from the power source as well as the antenna and cable system.

4 WHEN THE UNIT IS PLUGGED IN

- Never expose the unit to rain or water. **DO NOT OPERATE** if liquid has been spilled into the unit. Immediately unplug the unit, and have it inspected by a service technician. Fire and shock hazards can result from electrical shorts caused by liquid contact inside.
- Never drop or push any object through openings in the unit. Some internal parts carry hazardous voltages and contact can cause electric shock or fire hazard.
- Avoid placing the unit directly above or below your TV set as this may cause electrical interference. Keep all magnets away from electronic equipment.

5 USING ACCESSORIES

Use only accessories recommended by the manufacturer to avoid risk of fire, shock, or other hazards.

6 CLEANING THE UNIT

Unplug the unit. Then, use a clean, dry, chemically untreated cloth to gently remove dust or debris. **DO NOT USE** cleaning fluids, aerosols, or forced air that could over-spray, or seep into the unit and cause electrical shock. Any substance such as wax, adhesive tape, etc. may mar the cabinet surface. Exposure to greasy, humid, or dusty areas may adversely affect internal parts.

SERVICE

1 DO NOT SERVICE THIS PRODUCT YOURSELF

If, after carefully following the detailed operating instructions, this Video product does not operate properly, do not attempt to open or remove covers, or make any adjustments not described in the manual. Unplug the unit and contact a qualified service technician.

2 IF REPLACEMENT PARTS ARE REQUIRED

Make sure the service technician uses only parts specified by the manufacturer, or those having the same safety characteristics as the original parts. The use of unauthorized substitutes may result in fire, electric shock, or other hazards.

3 HAVE THE SERVICE TECHNICIAN PERFORM A SAFETY CHECK

After any service or repairs to the unit, request the service technician to conduct a thorough safety check as described in the manufacturer's service literature to insure that the video unit is in safe operating condition.

Table of Contents

Use
Now!

Important Safeguards and Precautions	2
Accessories	4
Loading the Batteries	4
Basic Connections (Antenna, VCR, TV)	4, 5
One Time VCR Setup (Language, VCR's Output Channel, Channel, Clock) ..	6, 7
Playback a Tape (Still picture, Frame by Frame picture, Slow Motion)	8
Record On a Tape	9
• One Touch Recording	9

Basic Operation

Enjoy
more!

Advanced Connections (Cable/DSS)	10
Copying Your Tapes (Dubbing)	11
Timer Recording	12, 13
• Timer Recording	12
Using VCR Buttons	12
• Review, Replace or Clear Program Contents	13
Timer Recording Using VCR Plus+® System	14 ~ 19
• Choose your connection type ..	14
• Cable Box Setup	15
• Auto VCR Plus+ System	16, 17
Channel Setup	16, 17
• Manual VCR Plus+ System	18
• VCR Plus+ System	19
Programming	19
Multi-Brand Control Feature	20, 21
Tape Operation	22 ~ 29
• Commercial Advance	22 ~ 24
• Movie Advance	25
• Search System	26 ~ 29
• Program End Search	26
• Program Index Search, Index Scan ..	27
• Auto Operation Functions	27
• Direct Access	28
• Repeat Play	29
• Zero Search	29
MTS Broadcast/ VHS Hi-Fi Stereo System	30, 31
• Stereo/SAP/Mono Broadcast ..	30
• Select Audio Mode	31
Special VCR Features	32 ~ 37
• Channel Caption	32, 33
• Time Stamp	34, 35
• Tape Position Display	36
• Remote Warning ON/OFF	36
• VCR Lock	36
• Weak Signal Display ON/OFF	37
• Auto Shut-Off	37

Advanced Operation

Other
Information!

Reset Language, Channels, Clock, VCR's Output Channel ..	38, 39
VCR & Cassette Information	40, 41
• Reset All VCR Memory Functions ...	40
• DST (Daylight Saving Time)	40
• Prevent Accidental Tape Erasure ..	40
• Record/Playback Time	40
• Head Cleaning	41
• Cleaning the VCR	41
• Specifications	41
• Features for a Quality Picture ..	41
On Screen Displays (OSD)	42, 43
• Function & Channel Display	42
• VCR Status & Clock Display ...	42
• Blank Tape/ No Video Signal Indication	42
• Warning and Instruction Displays ..	43
Before Requesting Service	44
Service Center List	45
Warranty	46, 47
Spanish (Español) Quick Use Guide	48, 49
Location of Controls	50, 51
Quick Use Guide (Playback, Recording)	Back Cover

For Your Information

Congratulations

on your purchase of one of the most sophisticated and reliable products on the market today. Used properly, it will bring you and your family years of enjoyment. Please fill in the information below. The serial number is on the tag located on the back of your VCR.

- Date of Purchase _____
- Dealer Purchased From _____
- Dealer Address _____
- Dealer Phone No. _____
- Model No. _____
- Serial No. _____

Accessories

- Remote Control
- Batteries 2 "AA"

LSSQ0204

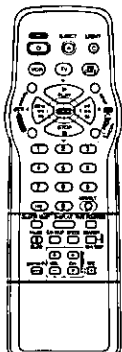
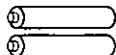

- RF Coaxial Cable



To order accessories, call toll free
1-800-332-5368.

Loading the Batteries

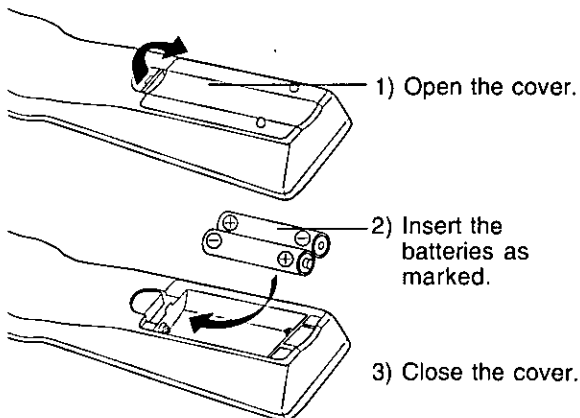

- Battery replacement caution**
 - Do not mix old and new batteries.
 - Do not mix alkaline with manganese batteries.

If your TV has AUDIO and VIDEO IN terminals, connect them to VCR for higher quality picture and sound. You can enjoy stereo sound even if your TV is not stereo by connecting a stereo amplifier to the VCR.

Connect VCR and TV with an AV Cable (not supplied) or a RF Coaxial Cable (supplied) as shown in the figure below.

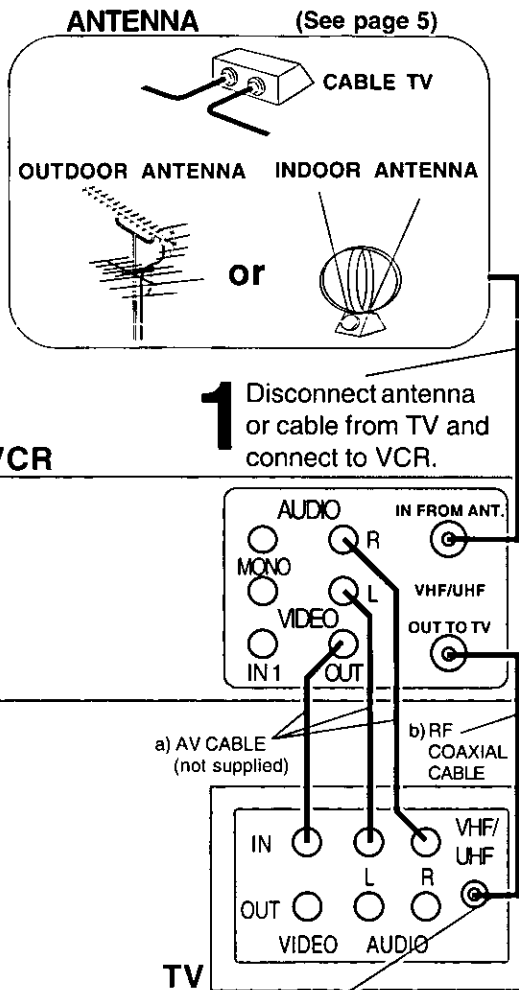

1 Disconnect antenna or cable from TV and connect to VCR.

a) AV CABLE (not supplied) b) RF COAXIAL CABLE

2 Connect VCR to TV with RF Coaxial Cable.

Notes

- 1) While connection b) (above) is sufficient, connection a) offers better sound and picture (especially with this model, you can enjoy Hi-Fi STEREO sound).
- 2) For both connections a) and b) proceed as follows:
 - To use VCR : VCR Power on, set TV to VIDEO.
 - To watch TV : VCR Power off, select channel on.
- 3) Set VCR Output to channel 3 or 4 (not an active station). (See page 6.)
Use the L Audio OUT jack for proper sound reproduction when connecting to a monaural TV.

WARNING

When using "Nut type" RF coaxial cables, tighten with fingers only. Overtightening may damage terminals.

1 Between ANT. and VCR

■ Case 1: Twin Lead Cable Only

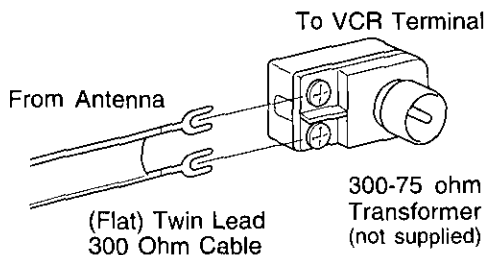

■ Case 2: Twin Lead & Coaxial Cables

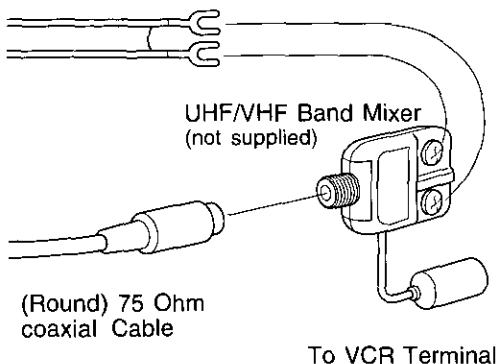

■ Case 3: Two Twin Lead Cables

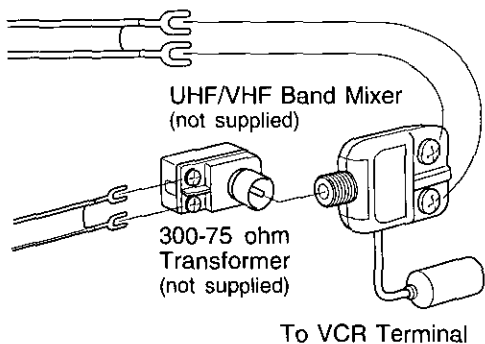

- If your TV has both post and plug-type VHF terminals, the post connection is recommended to minimize signal loss.

2 Between VCR and TV

■ Case 1: Screw & Plug Type Terminal

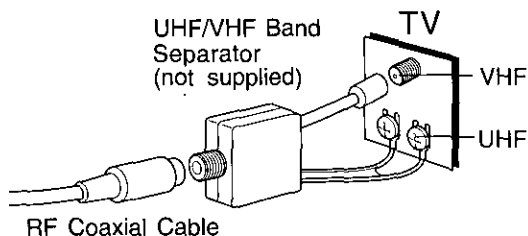

■ Case 2: Screw Type Terminal

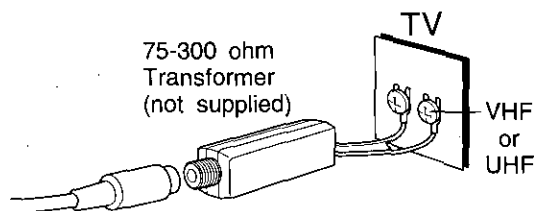

■ Case 3: Double Screw Type Terminal

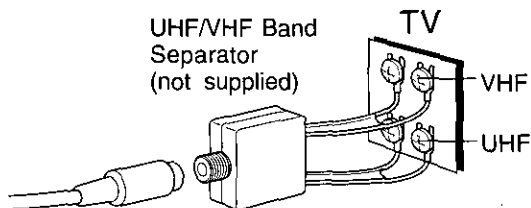

■ Case 4: Complex TV Terminal

TERMINALS ON BACK OF TV SET

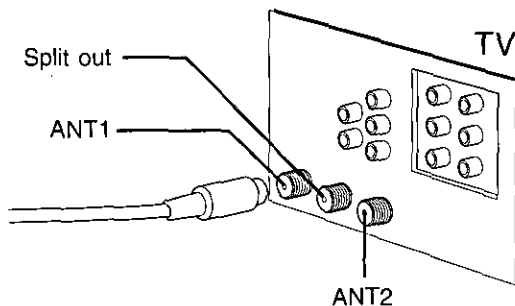

- Connect to one of the ANT terminals and select the same antenna number on the TV.

Note to CABLE system installer:
This reminder is provided to call the CABLE system installer's attention to Article 820-40 of the NEC in USA (and to the Canadian Electrical Code in Canada) that provides guidelines for proper grounding and, in particular, specifies that the cable ground shall be connected to the grounding system of the building, as close to the point of cable entry as practical.

FCC Warning: Any unauthorized changes or modifications to this equipment would void the user's authority to operate.

OneTime VCR Setup

When VCR is turned on the first time, setup mode is entered automatically.

Process of Setup

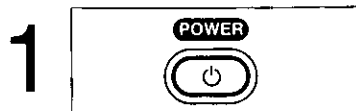

Turn the TV and VCR on.

Press POWER*.

Set TV Channel to CH 3.

- If using AV Cable connection, set TV to Video instead of channel. (See connection a) on page 4.)

Display SELECT LANGUAGE.

This display appears for first time setup only.

Select the language.

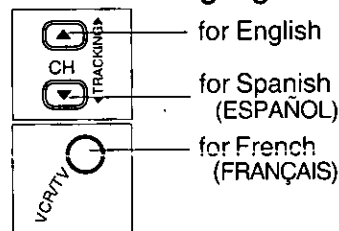

When using connection b) (see page 4), tune TV to VCR's output channel.

If there is beat or noise on CH3, change VCR's output channel to CH4 by pressing ACTION twice.

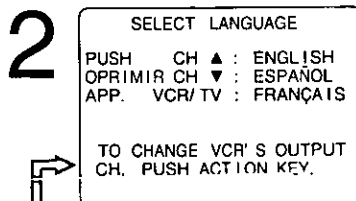

↓ Press ACTION

IF YOU PUSH ACTION KEY, VCR'S OUTPUT CH SWITCHES TO CH 4.

↓ Press ACTION

PLEASE TUNE YOUR TV TO CH 4.

After 3 seconds

- Always tune TV to this channel to monitor the VCR.
- If you used audio/video jack connection, tune the TV to its video input.
- If wrong language is set, do "Reset All VCR Memory Functions" steps on page 40.

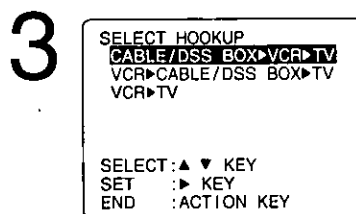

Select hookup.

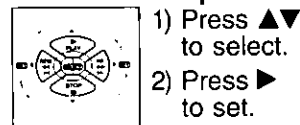

- If you selected "CABLE/ DSS BOX ▶ VCR ▶ TV," continue with step 4 and only the cable box output channel will be placed in memory..
- If not, go to step 6.

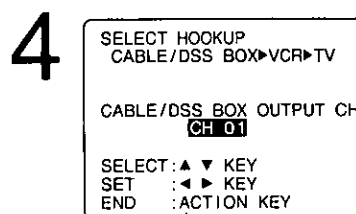

Select cable box or DSS receiver output channel.

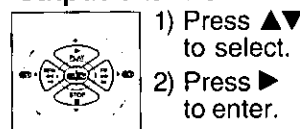

- If necessary, refer to cable box manual.
- If you used Audio/ Video jack connection to cable box, set "VIDEO OUT".

5 Turn on cable box and set it to PBS channel in your time zone.

- If you use DSS receiver, it must be turned off.

6

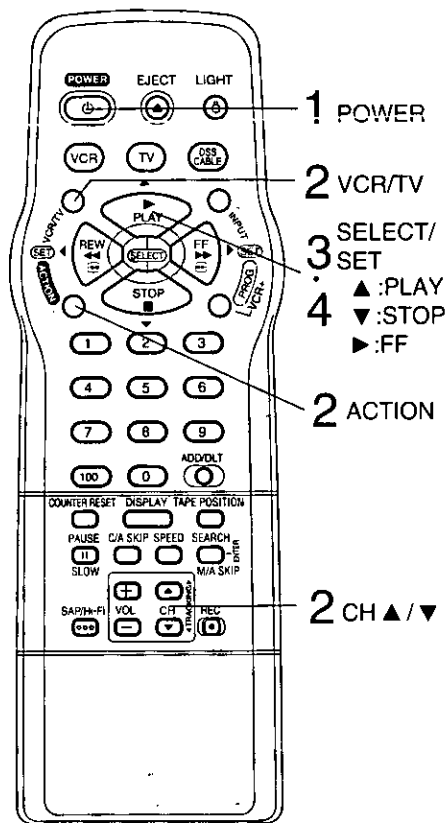

*Important: If the remote control POWER, ACTION, PROG/VCR+, CH▲/▼, POWERED keys, INPUT, SEARCH/MA SKIP or ADD/DLT button does not work when pressed, press the VCR button on the remote and try the button again.

6

CHANNEL/CLOCK AUTO SET
 CONNECT ANTENNA CABLE AND IF YOU USE A CABLE BOX, TUNE IT TO YOUR LOCAL PBS CH THEN...
 PLEASE PUSH CH UP KEY

Start Channel Auto Set and Clock Auto Set.

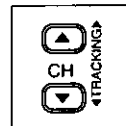

Press CH ▲.

CH AUTO SET PROCEEDING

AUTO CLOCK SET PROCEEDING

IMPORTANT NOTE FOR AUTO CLOCK SET

- Auto clock set is performed the first time the VCR is turned off each day. If used, a cable box must be left on and tuned to the PBS channel at the time VCR power is turned off if you want auto clock set to be done.
- If used, a DSS receiver must be turned off for auto clock set.
- If Cable Box or DSS receiver is connected to VCR via Audio/Video jacks, an RF coaxial cable must also be connected for auto clock set and channel auto set features to work.

Case 1 (Setup completed)

1/ 4/2000 TUE 12:00PM
 DST:ON
 SETTING : CH 02
 AUTO CLOCK SET COMPLETED
 END : PUSH CH UP KEY

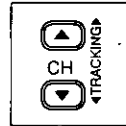

Press CH ▲ to exit.

- If your area observes DST (daylight saving time), but the time is incorrect; do the "Time Zone Adjust" steps on page 39.

Case 2 (Setup incomplete)

AUTO CLOCK SET IS INCOMPLETE
 PUSH ACTION TO SET CLOCK

Clock Setup incomplete. Set the clock manually.

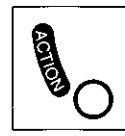

1) Press ACTION.

SET CLOCK
 1/ -- / -- -- DST:ON
 SELECT MONTH
 SELECT:▲ ▼ KEY
 SET :▶ KEY
 END :ACTION KEY

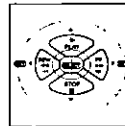

2) Press ▲▼ to select month.
 3) Press ▶ to set.

- Likewise, set date, year, time, DST (Daylight Saving Time).

To Make Corrections, repeatedly press ◀▶ to move to error, then correct.

SET CLOCK
 1/ 4/2000 TUE 12:00PM
 DST:ON
 SET COMPLETED
 SET :◀▶ KEY
 START :ACTION KEY



4) Press ACTION.
 (Clock starts.)
 • To exit this mode, press ACTION again.

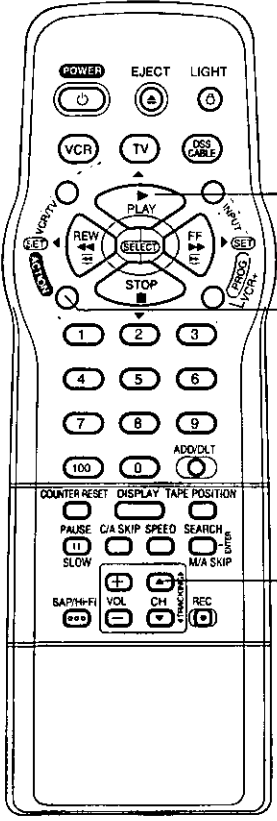

SELECT/SET
 ▲:PLAY
 ▼:STOP
 ◀:REW
 ▶:FF

ACTION

CH ▲

Notes

- VCR calendar is accurately maintained to Dec. 31, 2096 11:59PM.
- Channel auto set selects normal TV or Cable channels depending on your VCR hookup.
- To reset Language, Channels, Clock or VCR's Output Channel see pages 38 and 39.

Using ▲▼◀▶ keys

You can also operate the menu screen using VCR buttons.

When menu screens are displayed, the PLAY, STOP, REWIND, and FF buttons on the VCR and remote function as ▲▼◀▶ only with no tape inserted.

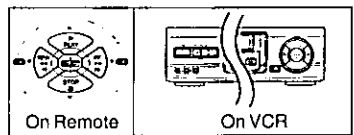

To display menu using VCR buttons, press CH ▲ and CH ▼ together.

▲ : PLAY ◀ : REW
 ▼ : STOP ▶ : FF

To exit the menu, repeat above.

Playback a Tape

✓ Check list before you begin.

- All connections are made.
- TV and VCR are plugged in.
- TV is turned on and set to CH3, 4 or Video on TV.
- Remote is in VCR mode.

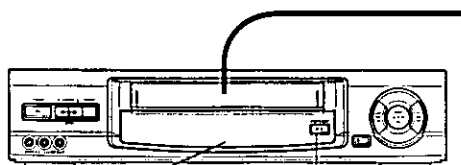

Multi Function Display STOP/EJECT

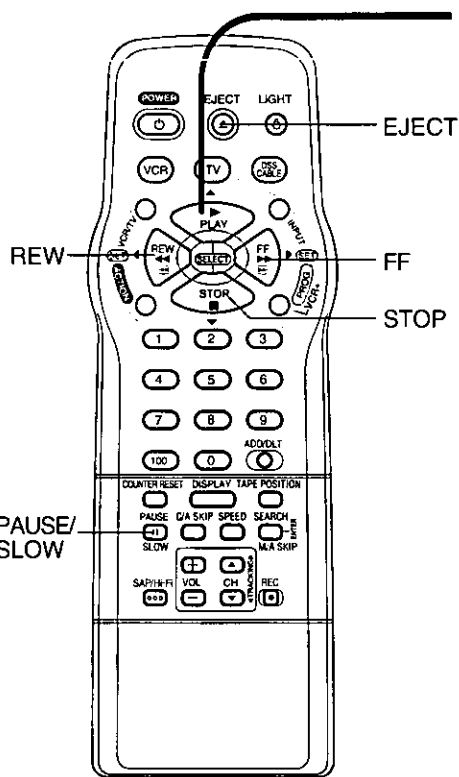

1

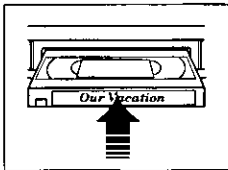

Insert a cassette.

- VCR power comes on and "VCR" appears on Multi Function Display.

2



Press PLAY.

- Or, if cassette has no record tab (see page 40), auto playback begins.

- To Find a Particular Scene
Forward Search --> Press FF. (To release, press PLAY or FF.)
Reverse Search --> Press REW. (To release, press PLAY or REW.)
- For Still (Freeze) picture --> Press PAUSE/SLOW. (To release, press PLAY.)
- For Frame by Frame picture --> Press PAUSE/SLOW in Still mode. (To release, press PLAY.)
- For Slow Motion --> Press and hold PAUSE/SLOW in Still mode. (To release, press PLAY.)

Notes

- These features work best in SP or SLP mode.
- The sound will be muted.
- To reduce picture noise, see "Manual Tracking Control" on page 41.
- After the VCR is in Still or Slow mode for 3 minutes, it will switch to Stop mode automatically to protect the tape and the video head.

- To stop --> Press STOP.
- To rewind tape --> Press REW in Stop mode.
- To fast forward tape --> Press FF in Stop mode.
- To eject tape --> Press EJECT on the remote or STOP/ EJECT on the VCR.

Note

- To prevent tape jam
Inspect your cassette tapes and remove any loose or peeling labels.

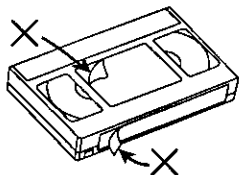

Playback using VCR controls

- 1 Insert a cassette.
- 2 Press PLAY.

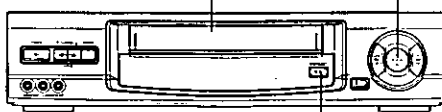

- Press to stop and/ or eject tape.

Record On a Tape

***Important:** If the remote control POWER, ACTION, PROG/VCR+, CH ▲/▼, NUMBERED keys, INPUT, SEARCH/M/A SKIP or ADD/HLT button does not work when pressed, press the VCR button on the remote and try the button again.

Playback/Recording

✓ Check list before you begin.

- All connections are made.
- TV is turned on and tuned to CH3, 4 or Video.
- Cassette record tab is in place.
- Remote in VCR mode.

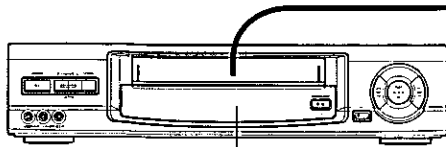

Multi Function Display

1

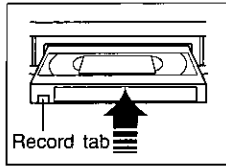

Record tab

Insert a cassette.

- VCR power comes on and "VCR" appears on Multi Function Display.

2

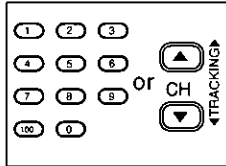

Select Channel.

Press CH ▲/▼* or NUMBERED keys.

- To select "LINE," see page 11.
- To select channels over 100, first press 100 key, then enter remaining two digits.

3

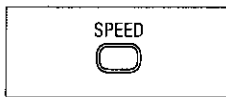

Select Recording speed.

(See page 40.)

Press SPEED.

- SP = Standard Play
- LP = Long Play
- SLP = Super Long Play
- Selected speed is displayed on TV screen and Multi Function Display.

4

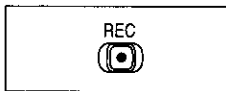

Start Recording.

Press REC.

- To edit out unwanted portions, press PAUSE/SLOW to pause and to resume recording.

■ To stop --> Press STOP

■ One Touch Recording

Press REC repeatedly to set the recording length (30 min. ~ 4 hours).

- The VCR turns itself off at a preset time.

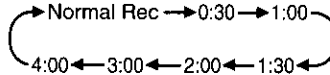

■ Record One Program While Watching Another

Press VCR/TV--> "VCR" disappears on Multi Function Display --> Select Channel at the TV.

■ Selecting Channel at the VCR

Press VCR/TV--> "VCR" appears on Multi Function Display --> Select Channel at the VCR (applies to connection b) only, see page 4).

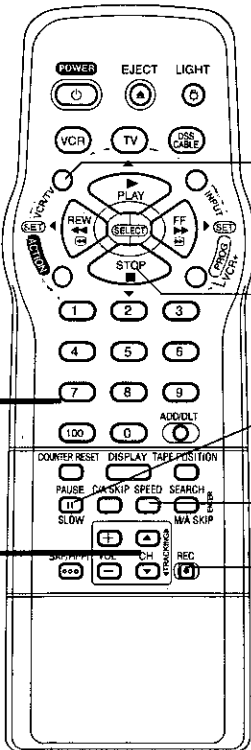

VCR/TV

STOP

PAUSE/SLOW

3 SPEED

4 REC

Note

After the VCR has been in Pause mode for 5 minutes, it will stop automatically to protect the tape and the video head.

This video recorder, equipped with the HQ (High Quality) System, is compatible with existing VHS equipment. Only use those tapes with the **VHS** mark. It is recommended that only cassette tapes that have been tested and inspected for use in 2, 4, 6, and 8 hour VCR machines be used.

Record using VCR controls

- 2 Select Channel. VCR/TV
- 1 Insert a cassette.
- 4 Start Recording.



■ Press to stop.

Advanced Connections

Be sure to tune TV to VCR output channel. (The same one you set on screen of TV: CH3 or CH4.)

All connections on these pages are made with 75 Ohm coaxial cables.

CATV Connection

■ With a Cable Box (Cable Box → VCR)

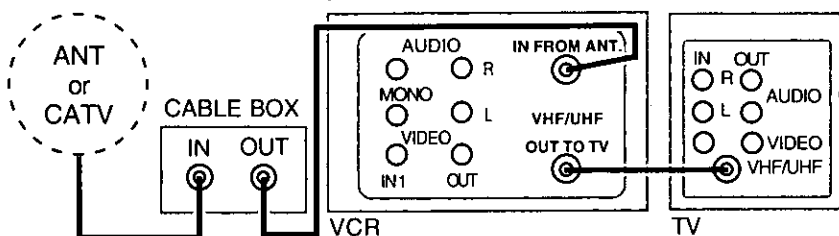

You Can

- record or view any (including scrambled) channel.
- use VCR Remote Control to select channels using Multi-brand control feature.

You Cannot

- view channel other than the one selected for any type of recording.
- do a Timer recording of a channel unless you select it at the cable box.

■ With a Cable Box (VCR → Cable Box)

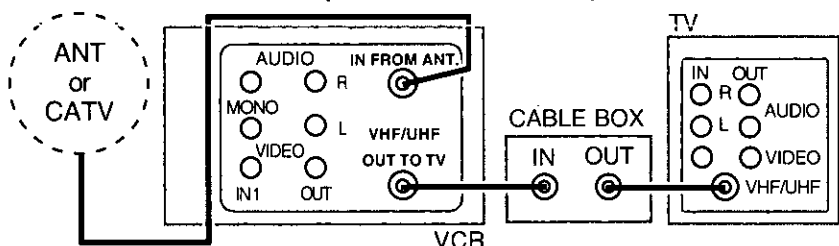

- view any (including scrambled) channel.
- use VCR Remote Control to select channels without using Multi-brand control feature.

- record scrambled channels.

■ With Two Cable Boxes

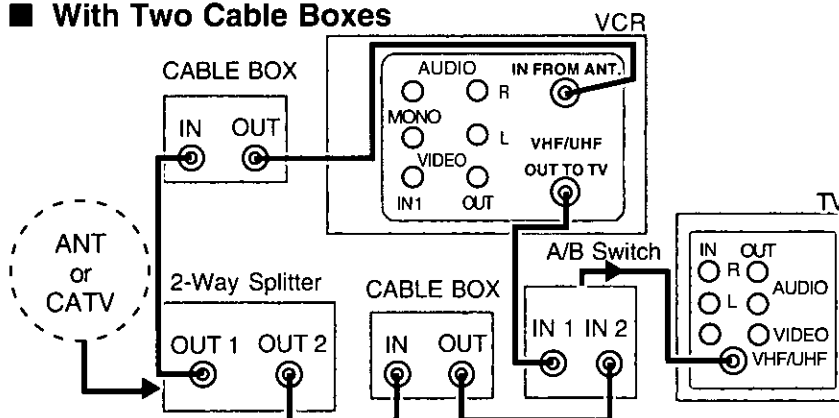

- record and view both scrambled and unscrambled channels if additional equipment is added. This connection requires: two converter boxes, an A/B switch, and a 2-way splitter.

- view channel other than the one selected for any type of recording.
- do a Timer recording of a channel unless you select it at the cable box.

DSS Connection

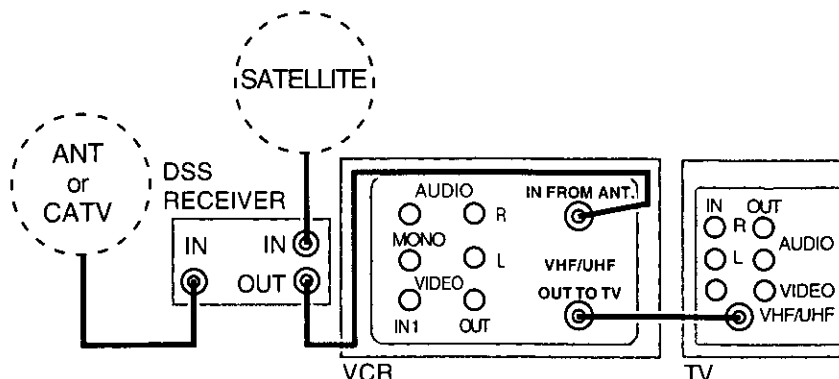

- record and view any (including scrambled) channel.
- use your VCR Remote Control to select channels using Multi-brand control feature.

- view channel other than the one selected for any type of recording.
- do a Timer recording of a channel unless you select it at the DSS box.

NOTE:
DSS receiver must be turned off to view cable box or antenna programs.

Copying Your Tapes (Dubbing)

Connections you'll need to make.

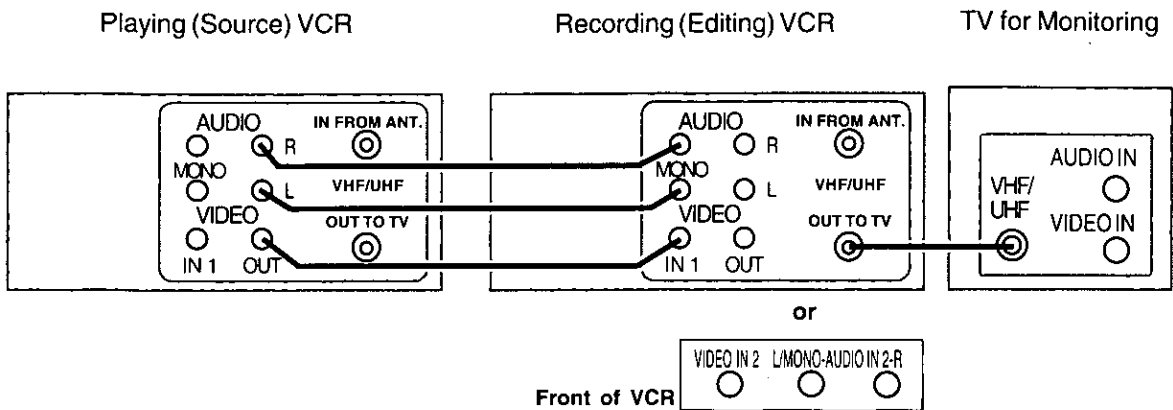

Playing (Source) VCR

Recording (Editing) VCR

1  **Insert pre-recorded tape.**

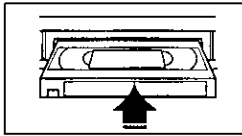
 **Insert blank tape with record tab.**

2 _____

 **Select LINE mode.**
Press INPUT.
(See "Selecting the Input Mode" below.)

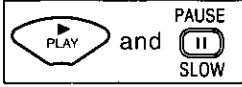
3  **Put in Standby mode.**
Press PLAY, then PAUSE/SLOW at starting point.

 **Put in Standby mode.**
Press REC, then PAUSE/SLOW immediately.

4  **Start dubbing.**
Press PLAY.

 **Start dubbing.**
Press PAUSE/SLOW.

5  **Stop dubbing.**
Press STOP.

 **Stop dubbing.**
Press STOP.

■ To Monitor Dubbing on Your TV

■ Selecting the Input Mode

- 1 Turn your TV on and tune to the Recording VCR channel (CH3 or CH4).
- 2 Set the VCR/ TV Selector on the Recording VCR to "VCR."

- Method 1: Press INPUT.
Channel Number <--> LINE1 <--> LINE2
- Method 2: Press CH ▲/▼. Display will change as below.

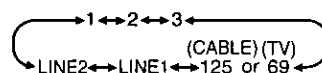

- "L1" or "L2" lights on Multi-Function Display (about 4 sec.) when LINE1 or LINE2 is selected.
- LINE1: For rear audio/video connection.
- LINE2: For front audio/video connection.

Note Dubbing tapes protected with Copy Guard will have poor quality results.

Caution: Unauthorized exchanging and/or copying of copyrighted recordings may be copyright infringement.

Timer Recording

You can set up to 8 programs to be recorded while you are away.

1

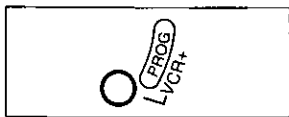

Display SET PROGRAM.

Press PROG/VCR+.*

You can also display Program screen from Menu.

- 1) Press ACTION to display Menu.
- You can also set up using VCR buttons. See the bottom right of this page.
- 2) Press ▲▼ and ► to select and set SET UP FEATURE.
- 3) Press ► to display Program screen.
- 4) Go to step 3.

2

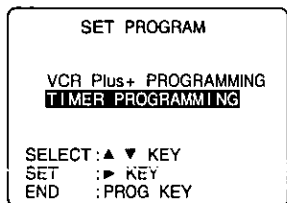

Display Program screen.

- 1) Press ▲▼ to select TIMER PROGRAMMING.
- 2) Press ► to display.



- If a program is already in memory, press ▲▼ and ► to select an unused program number.

• You may not use the VCR buttons on "SET PROGRAM" screen.

3

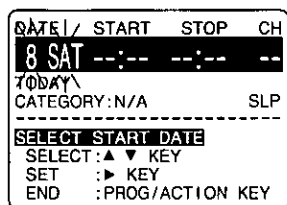

Set the recording DATE.

- 1) Press ▲▼ to select.
- 2) Press ► or ◀ to set.



- 1-31 = One time
- DAILY = MON-FRI
- WEEKLY = Same time once a week

Example
 Today → 8-9.....31-1-2.....6
 WEEKLY (SAT) WEEKLY (MON) WEEKLY (SUN)

Repeat step 3 to set: start time, stop time Channel (or LINE for outside source), Category**, tape speed (SP, LP, SLP).

4

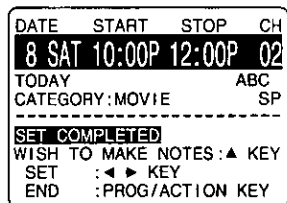

Make the notes.

- If not wanted, go to step 5.

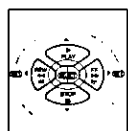

- 1) Press ▲ to begin.
- 2) Press ▲▼ to select.
- 3) Press ► to set.

• Characters will change in the following order.

A→B→C→...→Z→BLANK→→→&→
 9→...→2→1→0→+→/→

- 4) Press PROG/VCR+ (or ACTION) to end.

Continued on the next page.

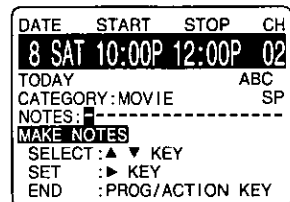

Important notes when using a DSS receiver

- When recording programs via a DSS receiver, the DSS receiver must be left on.
- When recording programs via an antenna or cable, the DSS receiver must be turned off.



Check list before you begin.

- All connections are made. (See pages 4-5.)
- TV and VCR are plugged in and turned on.
- VCR/TV selector is set to "VCR."
- Clock is set to correct time.
- Record tab in place. (See page 40.)
- Remote in VCR mode.
- Use not in REC, REC TIME or A/V Dubbing.

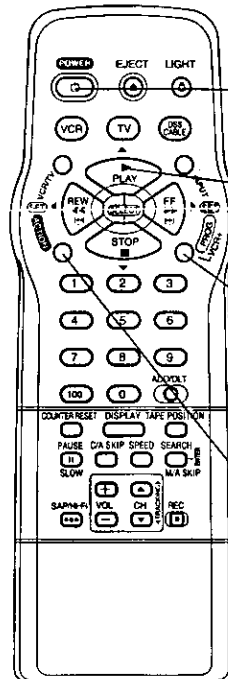

- 6 POWER
- 1 SELECT/SET
- ▲:PLAY
- ▼:STOP
- 4 ◀:REW
- ▶:FF
- 1 PROG/VCR+
- 4
- 5
- 1 ACTION
- 4
- 5

** Category Items
 N/A(not applicable), SPORTS, MOVIE, COMEDY, MUSIC, DRAMA

Timer Recording Using VCR Buttons.

Using ▲▼◀▶ keys

You can also operate the menu screen using VCR buttons.

When menu screens are displayed, the PLAY, STOP, REWIND, and FF buttons on the VCR and remote function as ▲▼◀▶ only with no tape inserted.



To display menu using VCR buttons, press CH ▲ and CH ▼ together.

To exit the menu, repeat above.

***Important:** If the remote control POWER, ACTION, PROG/VCR+, CH▲/▼, NUMBERED keys, INPUT, SEARCH/ M/A SKIP or ADD/HLT button does not work when pressed, press the VCR button on the remote and try the button again.

5

P	DT	START	STOP	CH	SPD
1	8	10:00P	12:00P	02	SP
2	---	---	---	---	---
3	---	---	---	---	---
4	---	---	---	---	---

CANCEL: ADD/HLT KEY
 SELECT 1-8: ▲ ▼ KEY
 ENTER: ► KEY
 END: :PROG/ACTION KEY

End the program.

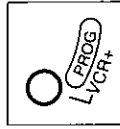

- 1) Press PROG/VCR+ (or ACTION).
- If start time of programs overlap, these programs will flash.

To Enter More Programs

Press ▲▼ to select, and ► to display a blank program number. Then repeat steps 3 and 4.

- 2) Press PROG/VCR+ (or ACTION) again to exit.

To cancel Timer Recording (Recording is in progress)

Press POWER and then STOP within 10 seconds to cancel the Timer recording. (The TIMER indicator goes out on Multi Function Display.)

6



Multi Function Display

Set the timer.

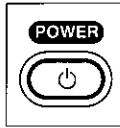

Press POWER off.

- When recording programs via a cable box, make sure the cable box is left ON and tuned to the desired channel.

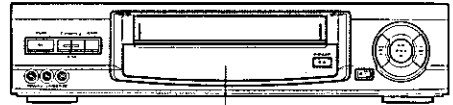

Multi Function Display

Review, Replace or Clear Program Contents:

(Recording is not in progress)

a

Repeat steps 1~2 on page 12.

b

P	DT	START	STOP	CH	SPD
1	DAY	9:00A	12:00A	03	SP
2	8	10:00P	12:00P	02	SP
3	10	8:00P	9:00P	10	SP
4	SU	9:00P	10:00P	L1	LP

CANCEL: ADD/HLT KEY
 SELECT 1-8: ▲ ▼ KEY

Select program.

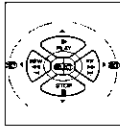

- 1) Press ▲▼ to select number.

c

To Replace program...

DATE	START	STOP	CH
8 SAT	10:00P	12:00P	125
70DAY\ ABC SP			
CATEGORY: MOVIE			
NOTES: STAND BY ME			
SELECT START DATE			
SELECT: ▲ ▼ KEY			
SET: : ► KEY			

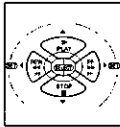

- 1) Press ► to display.
- 2) Press ▲▼◀▶ to set new program contents.

To Clear program...

P	DT	START	STOP	CH	SPD
1	---	---	---	---	---
2	8	10:00P	12:00P	02	SP
3	10	8:00P	9:00P	10	SP
4	SU	9:00P	10:00P	L1	LP

SELECT 1-8: ▲ ▼ KEY
 ENTER: ► KEY

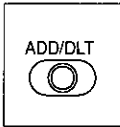

- 1) Press ADD/HLT.

d

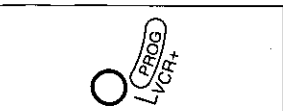

End the program.

- 1) Press PROG/VCR+ (or ACTION).
- If there are programs, press POWER off.

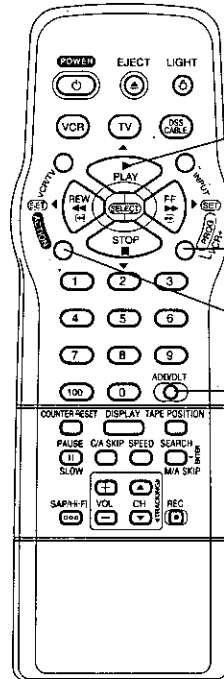

- SELECT/SET
- b ▲: PLAY
 - ▼: STOP
 - c ◀: REW
 - ▶: FF
 - d PROG/VCR+
 - d ACTION
 - C ADD/DELETE

Timer Recording Using VCR Plus+ System

VCR Plus+ System is ...

a feature that allows you to set most items of a timer recording by simply entering a special code number (PlusCode programming number) found in TV GUIDE and selected newspaper TV listings.

Process of Recording



Find the type of connection you use from the following diagrams and proceed to the page number indicated to begin set up.

Cable box → VCR → TV connection

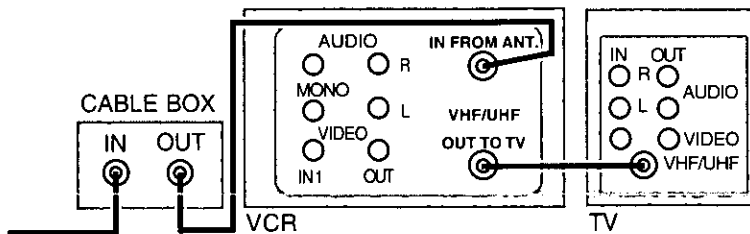

Note: You can not operate "Auto VCR Plus+ System Channel Setup" if type A connection is used.

A DSS box → VCR → TV connection

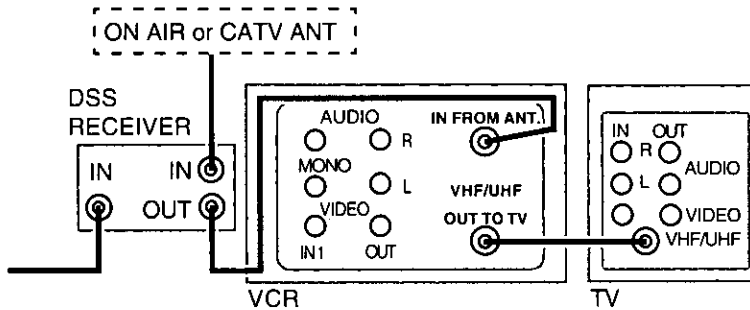

Setup on page

15

Programming on page

19

VCR → TV connection

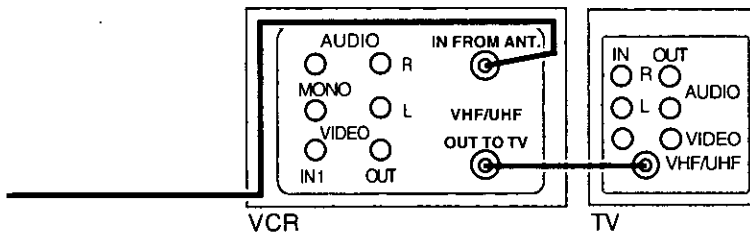

Setup on page

16

B VCR → Cable box → TV connection

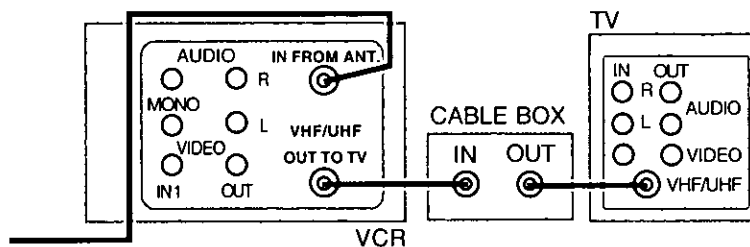

*Important: If the remote control POWER, ACTION, CONNECTION, CH ▲/▼, CH ▲/▼, POWER, ACTION, CONNECTION, CH ▲/▼, CH ▲/▼, INPUT, SEARCH/ M/A SKIP or ADD/DLT button does not work when pressed, press the VCR button on the remote and try the button again.

Cable Box Setup

Process of Recording

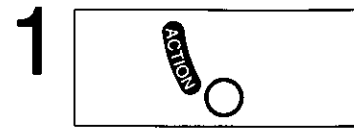

Display MENU.

Press ACTION.*

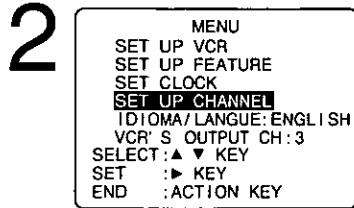

Select SET UP CHANNEL.

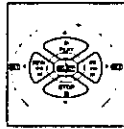

- 1) Press ▲▼ to select.
- 2) Press ► to display.

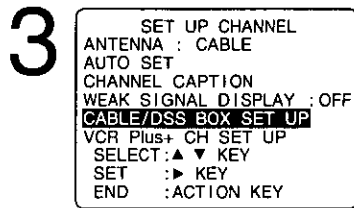

Select CABLE/DSS BOX SET UP.

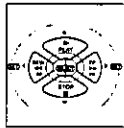

- 1) Press ▲▼ to select.
- 2) Press ► to display.

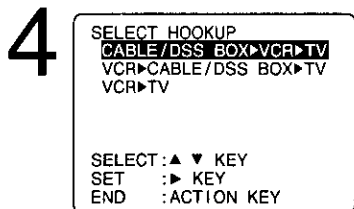

Select your hookup method.

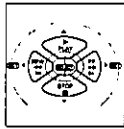

- 1) Press ▲▼ to select.
- 2) Press ► to set.

- If CABLE/DSS BOX ► VCR ► TV, go to step 5.
- If other, press ACTION three times and go to page 16.

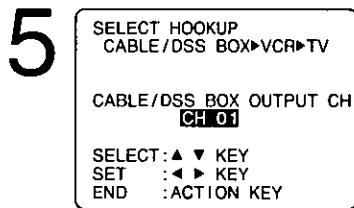

Select cable box or DSS receiver output channel.

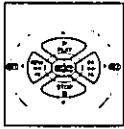

- 1) Press ▲▼ to select.
- 2) Press ► to enter.

- If necessary, refer to your Cable Box/DSS manual.
- If you are using Audio/Video jack connections, select and set "VIDEO OUT" as output channel.

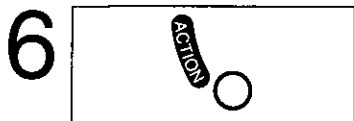

End setup.

Press ACTION twice.

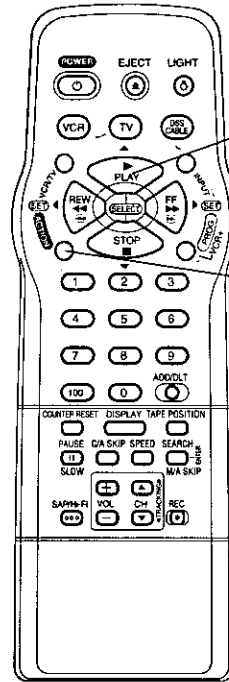



- 2 SELECT/SET
- 5 ▲:PLAY
▼:STOP
►:FF
- 1 ACTION
- 6

Timer Recording Using VCR Plus+ System

VCR Plus+®, PlusCode and ALL SET are registered trademarks of Gemstar Development Corporation. The VCR Plus+ system is manufactured under license from Gemstar Development Corporation.

Auto VCR Plus+ System Channel Setup (Part 1)

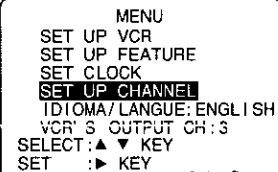
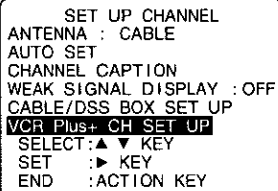
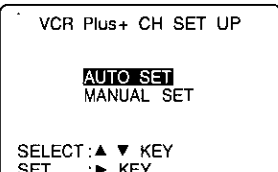
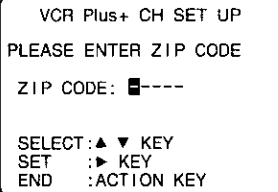
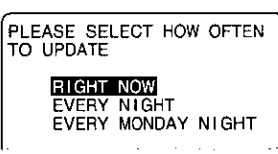
In order for VCR to read VCR Plus+ code, some set up is required. Guide (VCR Plus+) channel number is assigned to each local broadcast and cable station on, it is necessary to program the VCR with local channel information. To receive VCR Plus+ channels automatically, perform the steps below. Or, see "Manual VCR Plus+ System Channel Setup" section on page 18.

- 1**  **Display MENU.**
Press ACTION.*
- 2**  **Display SET UP CHANNEL.**
1) Press ▲▼ to select.
2) Press ► to display.
- 3**  **Display VCR Plus+ CH SET UP.**
1) Press ▲▼ to select.
2) Press ► to display.
- 4**  **Select AUTO SET.**
1) Press ▲▼ to select.
2) Press ► to set.
- 5**  **Enter Zip Code.**
1) Press ▲▼◀▶ to select and enter each number.
2) Press ► or ACTION to set.
- 6**  **Select Update Frequency.**
1) Press ▲▼ to select.
2) Press ► to set.
- 7**  **End setup.**
Press ACTION.
* Make sure to leave VCR off (overnight.).

Process of Recording

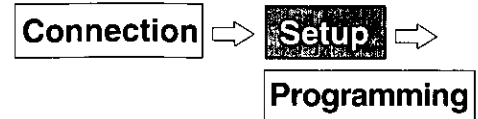

Important Note

- The "One Time VCR Setup" section on pages 6 and 7 must be completed before the "Auto VCR Plus+ System Channel Setup" section can be done. If any part of the setup is not completed, a warning screen appears.
- If your VCR connection type changes from type A to B, repeat steps 1-4 of page 15 and select VCR►CABLE/DSS► TV before proceeding with these steps.
- Complete this page only if type B connection is used.

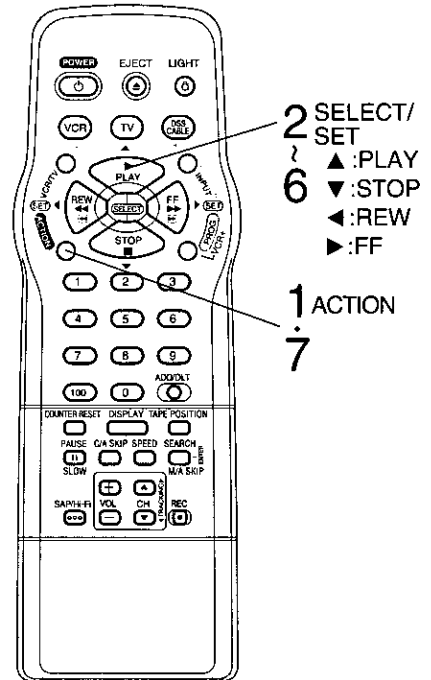

Notes

- Make each entry within 5 minutes or VCR will leave this mode.
- Once local channels have been programmed, they will stay in memory, even in the case of a power failure.
- "SET" will flash on Multi Function Display during Auto VCR Plus+ System Setup.
- If the start time for a timer recording comes up during Auto VCR Plus+ System Setup, the timer recording will have priority.

***Important:** If the remote control POWER, ACTION, PROG/VCR, CH▲/▼, NUMBERED keys, INPUT, SEARCH/ M/A SKIP or ADD/DLT button does not work when pressed, press the VCR button on the remote and try the button again.

Auto VCR Plus+ System Channel Setup (Part 2)

Before you perform the following steps, you should have:

- completed "Auto VCR Plus+ System Channel Setup (Part 1)" on page 16.
- left VCR off overnight, and turned it back on after 9:00 AM the next day.

1 If channel updating was successful...

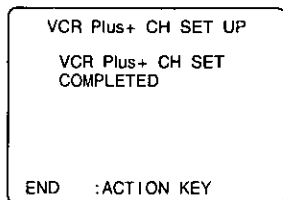

Exit this mode.
Press ACTION.



If VCR could not distinguish channel map...

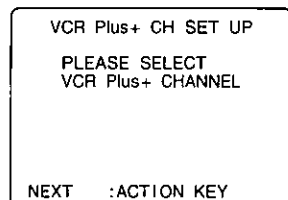

Display SELECT VCR Plus+ CH.

1) Press ACTION to display.
2) Continue with step 2.



2

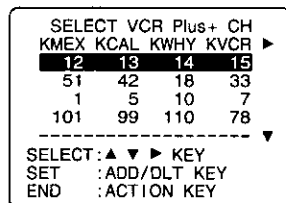

Select channel map for your area.

1) Press ▲▼ ◀▶ to select.
2) Press ADD/ DLT to set.

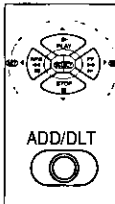

3

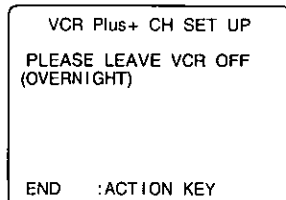

End Setup.

Press ACTION.

• Make sure to leave VCR off (overnight).

Channel map will be updated overnight. If it was successful, "VCR Plus+ CH SET COMPLETED" appears on screen. And then, press ACTION to exit.

Repeat these steps as necessary.

If Auto Setup fails, do "Manual VCR Plus+ System Channel Setup" section on page 18.

Process of Recording

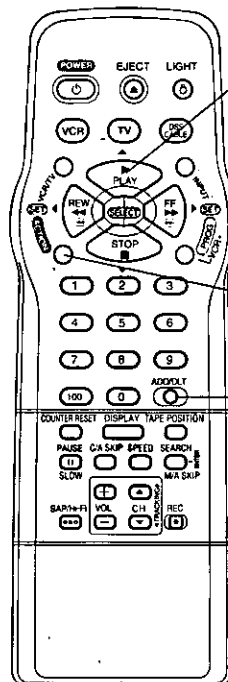
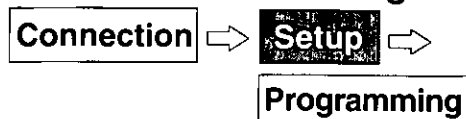

2 SELECT/ SET
▲:PLAY
▼:STOP
◀:REW
▶:FF

1 ACTION
3

2 ADD/ DELETE

Timer Recording Using VCR Plus+ System

To Change or Update Auto VCR Plus+ System Channel Setup

(E.g. you selected the wrong channel map, or your zip code channel.)

a Do "Auto VCR Plus+ System Channel Setup (Part 1)" steps 1-4 on page 16.

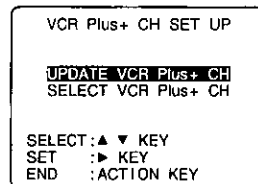

b Press ▲▼ to select UPDATE VCR Plus+ or SELECT VCR Plus+ CH, then press ▶.

c If you selected UPDATE VCR Plus+ CH, perform steps 5-7 in the "Auto VCR Plus+ System Channel Setup (Part 1)" section on page 16.

If you selected SELECT VCR Plus+ CH, perform steps 2-3 in the "Auto VCR Plus+ System Channel Setup (Part 2)" section on this page.

Manual VCR Plus+ System Channel Setup

- Before you begin, complete "Channel Setup Preparations" below right.

Important Note

- If your VCR connection type changes from type A to B on page 14, repeat steps 1-4 of page 15 and select VCR ► CABLE/DSS ► TV before proceeding with these steps.

1 Do "Auto VCR Plus+ System Channel Setup (Part 1)," steps 1-3 on page 16.

2

VCR Plus+ CH SET UP

AUTO SET
MANUAL SET

SELECT: ▲ ▼ KEY
SET : ► KEY
END : ACTION KEY

Select MANUAL SET.

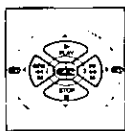

- 1) Press ▲▼ to select.
- 2) Press ► to set.

IMPORTANT NOTE:

For step 3, use the list you prepared. You may leave lines blank if you don't receive that station, or if the GUIDE CH number and the RECEIVE CH numbers are the same.

3

VCR Plus+ CH SET UP

GUIDE CH	RECEIVE CH
► 01	--
02	--

SELECT: ▲ ▼ KEY
SET : ► KEY
END : ACTION KEY

Select VCR Plus+ channels.

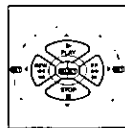

- 1) Press ► to move cursor to right column.
- 2) Press ▲▼ to change RECEIVE CH number.
- 3) Press ◀ to set.
- 4) Press ▲▼ to scroll up/down GUIDE CH column.

- Repeat step 3 until list is complete.

To make corrections,

Press ▲▼ and ► to move to error, then ▲▼ to change, or ADD/DLT* to erase number.

4

End setup.

Press ACTION three times.

Process of Recording

Connection ⇒ Setup ⇒

Programming

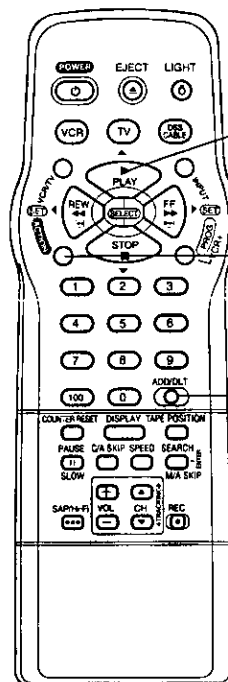

- 2 SELECT/SET
- 3 ▲:PLAY
▼:STOP
◀:REW
▶:FF

4 ACTION

3 ADD/DELETE

Channel Setup Preparations

In order to complete step 3 left, make a local channel list (see example below).

You will need the following:

- A line up of normal TV and/ or Cable stations and the channel number you receive them on.
- A list of Guide (VCR Plus+) channel numbers for the stations you receive found in TV Guide and selected newspapers.

- 1 Make a 3-column chart. In the left column, write the name of all the stations you receive.
- 2 In the middle column, write each station's Guide (VCR Plus+) number from TV Guide.
- 3 In the right column, write the channel number your TV receives the station on.

EXAMPLE ONLY

Broadcast or Cable Station Name	Assigned Guide (VCR Plus+) channel no.	Channel no. your TV receives the station on
HBO	33	15
Nickelodeon	38	20
CBS	04	04
FOX	11	

Notes

- Make each entry within 5 minutes or the VCR will exit this mode.
- Once local channels have been programmed, they will stay in memory, even in the case of a power failure.

***Important:** If the remote control POWER, ACTION, PROG/VCR+, CH▲/▼, NUMBERED keys, INPUT, SEARCH/ M/A SKIP or ADD/HLT button does not work when pressed, press the VCR button on the remote and try the button again.

Check list before you begin.

- The clock is set.
- VCR Plus+ System Setup is complete (see pages 14~18).

Process of Recording



VCR Plus+ System Programming

1  **Display SET PROGRAM.**
Press PROG/VCR+.*

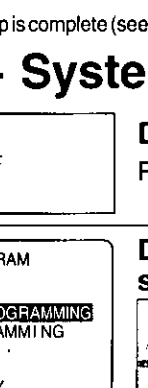
2  **Display VCR Plus+ screen.**
1) Press ▲▼ to select.
2) Press ► to display.

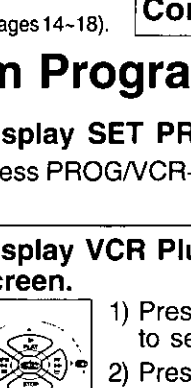
3  **Enter PlusCode programming number.**
1) Press Numbered keys.
2) Press PROG/VCR+ to lock in the program.

To make corrections, press ◀ repeatedly to delete the PlusCode programming number.

VCR Plus+ SYSTEM
ONCE
DAILY (MON-FRI)
WEEKLY
SELECT: ▲▼ KEY
SET: ► KEY
END: PROG KEY

Enter record frequency.
1) Press ▲▼ to select program type.
2) Press ► to set.

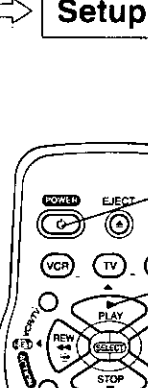
4  **Select Category.****
1) Press ▲▼ to change.
2) Press ► to set.

Change record speed.
Repeat 1) and 2).

5 **Make notes. -----> Do step 4 on page 12.**
• If not wanted, go to step 6.

6  **End programming.**
1) Press PROG/VCR+ (or ACTION).
To cancel press ADD/HLT.
2) Press PROG/VCR+ (or ACTION) again to exit.

7  **Set timer.**
Press POWER off.

Multi Function Display

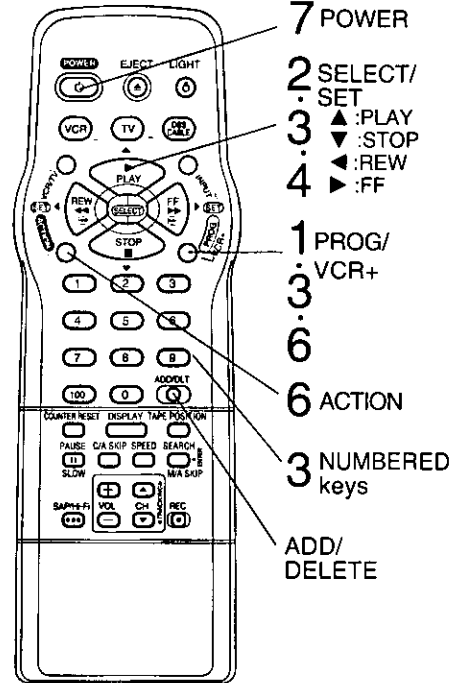

** Category Items
N/A(not applicable), SPORTS,
MOVIE, COMEDY, MUSIC, DRAMA

Use normal Timer Recording steps if:

- the PlusCode programming number for a program is not listed.
- you anticipate the program, such as a sporting event, to run over the scheduled stop time.

See page 13 to:

- cancel a timer recording in progress.
- replace program contents.
- review or clear program contents once set.

Important notes for DSS/Cable Box users

- When recording via DSS, the receiver, must be left on.
- When recording via cable or antenna, DSS receiver must be off.

Notes

- Avoid overlapping program times.
- You can obtain unlisted PlusCode numbers by calling 1 - 900 - 454 - 7587. Call costs approximately \$.95 per minute.

Timer Recording Using VCR Plus+ System

Multi-Brand Control Feature

The Remote Control may be set up to control some TV or Cable/DSS Receiver functions.

Multi-Brand Control Setup

1 Find your TV, Cable or DSS Receiver Brand Code Number on following page.

2 Setup for TV

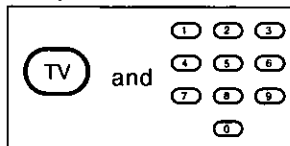

Setup remote.

Hold down TV and enter code with NUMBERED keys.

Setup for Cable or DSS

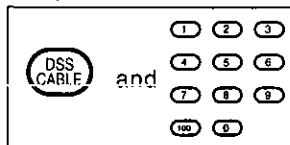

Hold down DSS/CABLE and enter code with NUMBERED keys.

- For code 100 or greater, press the 100 key first, then remaining digit. E.g. for 102, press 100, then press 0, and then press 2.

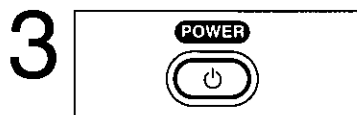

Confirm code entry.

Press POWER to turn selected unit on or off.

- See table below for list of controllable functions in each mode.

Notes

- Please repeat Multi-Brand Control setup after replacing remote control batteries.
- The remote control will not operate all TVs, Cable Boxes, and DSS receivers made by manufacturers listed. If you get no results, your particular brand cannot be controlled.

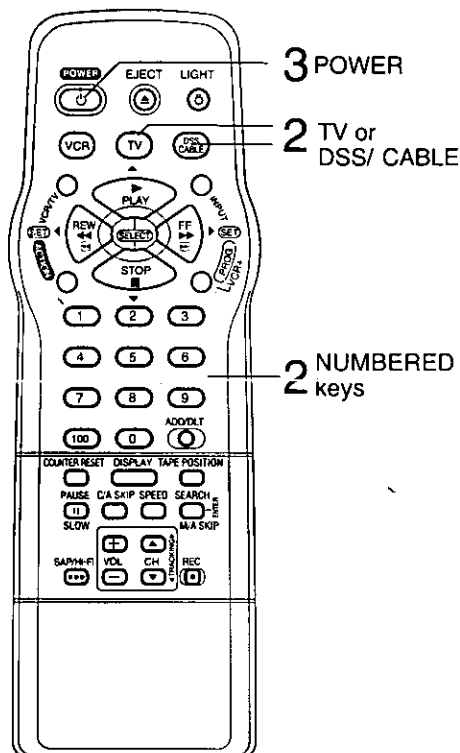

Using the Multi-Brand Control

After remote control is setup, you can select VCR, TV, or DSS/CABLE for the desired function.

Press **VCR** or **TV** or **DSS/CABLE** on the remote control.

This table shows which buttons are available for each mode.

Mode \ Available Buttons	VCR	TV	CABLE/ DSS
VCR	All Functions	VOL UP/DOWN	—————
TV	VCR/TV, PLAY, STOP EJECT, SAP/Hi-Fi, DISPLAY, FF, REW, PAUSE/SLOW, REC, SPEED, COUNTER RESET TAPE POSITION, C/A SKIP	POWER, INPUT, NUMBERED keys, ENTER, CH UP/ DOWN, VOL UP/DOWN	—————
CABLE/ DSS	VCR/TV, PLAY, STOP EJECT, SAP/Hi-Fi, DISPLAY, FF, REW, PAUSE/SLOW, REC, SPEED, COUNTER RESET TAPE POSITION, C/A SKIP	VOL UP/ DOWN	POWER, ENTER, NUMBERED keys (except 100key), CH UP/ DOWN

Note In TV or DSS/ CABLE mode, it may be necessary to press ENTER after pressing NUMBERED keys for channel selection.

TV Brand Code Numbers

Panasonic	01, 02	Sylvania	05	JVC	11
Quasar	01, 02	Sharp	06, 07	Hitachi	12
RCA	03	Sony	08	Mitsubishi	07, 13
GE	03	Toshiba	09	Samsung	14
Zenith	04	Sanyo	10	Gold Star	15, 16, 17
Magnavox	05	Fisher	10		

Cable Box Brand Code Numbers

Archer	05, 06, 01, 44, 63, 91, 126	Quest	05, 06
Cabletenna	01, 44, 63, 91, 126	Radio Shack	51, 44, 59, 75, 126
Cableview	63, 44, 42, 30, 52, 04, 124, 126	RCA	16, 17, 97, 109
Century	51, 44, 59, 75, 126	Realistic	51, 44, 59, 75, 126
Citizen	63, 44, 42, 30, 52, 04, 124, 126	Recoton	51, 44, 59, 75, 126
Curtis	08, 09, 61, 53, 87	Regal	14, 15, 28, 41, 102, 103, 104, 108, 130
Diamond	01, 44, 63, 91, 126	Regency	28, 130
Drake	67	Rembrandt	01, 32, 39, 42, 44, 63, 126
Eagle	13, 22, 58, 62, 20, 40, 26, 107	Salora	68
Eastern	28, 130	Samsung	05, 32, 40, 42, 06
GC Brand	63, 44, 42, 30, 52, 04, 124, 126	Scientific Atlanta	08, 09, 61, 53, 87
Gemini	04, 124	Sheritech	27
General Electric	57, 01	Signal	26, 112
General Instruments	01, 02, 03, 04, 34, 55, 83, 106, 65, 67, 68, 115, 117, 118, 124, 91	SL Marx	32, 40, 42, 06, 43, 44, 52, 63, 126
Hamlin	14, 15, 28, 41, 102, 103, 104, 108, 130	Sprucer	16, 17, 97, 109
Hitachi	31	Standard Components	32, 39, 42, 44, 126
Jasco	04, 124	Stargate	32, 40, 63, 44, 42, 30, 52, 04, 06, 124, 126
Jerrold	01, 02, 03, 04, 34, 55, 83, 106, 65, 67, 68, 115, 117, 118, 124, 91	Sylvania	19
Macom	31	Teknika	74
Magnavox	26, 112	Telecaption	77, 127
Matsushita	16, 17, 97, 109	Television	32, 40, 42, 06
Movietime	32, 39, 42, 44, 126, 38, 40	Texscan	18, 19
NEC	38, 40, 32	Tocom	33, 34, 01, 42, 66, 91
NOVAVISION	08, 09, 61, 53, 87	Toshiba	36
NSC	38, 40, 32	Uniden Satelite	65
Oak	46, 11, 129	Unika	01, 44, 63, 91, 126
Oak Sigma	46, 11, 129	Universal	42, 43, 44, 52, 63, 126
Panasonic	16, 17, 97, 109	Videoway	07, 23, 50, 129
Philips	07, 13, 20, 23, 24, 50, 128, 129	Vid Tech	64
Pioneer	05, 06	Vidtek	64
Pulsar	63, 44, 42, 30, 52, 04, 124, 126	Viewstar	13, 22, 58, 62, 20, 40, 26, 107
		Zenith	07, 23, 50, 129

DSS Brand Code Numbers

Toshiba	92	Panasonic	96
Hitachi/ Hughes	93	RCA	97
Magnavox/ Uniden 1	94	Sony	98, 105
Magnavox/ Uniden 2	95		

Important Notes

- Due to changes in infra-red commands used by manufacturers, some brands have several codes. If your unit does not respond to the first code, please try the next one.
- Some TV, Cable Box and DSS Box brands require you to turn on the power manually.
- Not all functions listed may be controlled by this remote control.

Tape Operation

COMMERCIAL ▶▶ ADVANCE®

COMMERCIAL ▶▶ ADVANCE® detects and marks the beginning and end points of commercials on your tape for recordings over 15 minutes in length. When COMMERCIAL ▶▶ ADVANCE® marked tape is played back, the VCR automatically advances through the commercial segments at high speed. You can also set this feature to Manual so as to have more control over the advance process. The effectiveness of this system can vary due to differences in the way television stations broadcast. See page 24 for answers to the most commonly asked questions about this feature.

Check list before you begin.

- All connections are made.
- One time Setup completed.
- VCR is plugged in.
- TV is turned on and set to CH3, 4 or Video on TV.

COMMERCIAL ▶▶ ADVANCE® Marking

When C/A RECORD: ON, VCR automatically rewinds the tape after a recording has been made and marks the beginning and end of any detected commercial blocks. After marking is done, the tape is returned to the end of recording. Commercials are not erased from the tape.



Display MENU.
Press ACTION.*

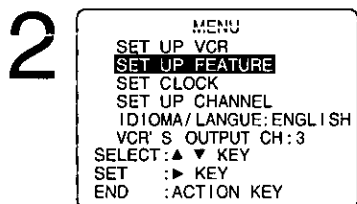

Display SET UP FEATURE.

- 1) Press ▲▼ to select.
- 2) Press ► to display.

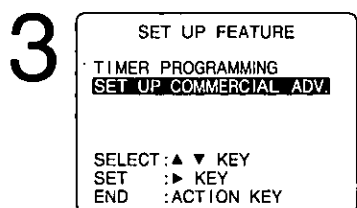
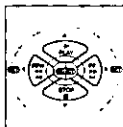

Display SET UP COMMERCIAL ADV.

- 1) Press ▲▼ to select.
- 2) Press ► to display.

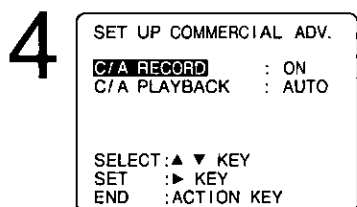
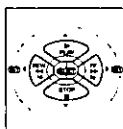

Set ON or OFF.

- 1) Press ▲▼ to select.
- 2) Press ► to set.

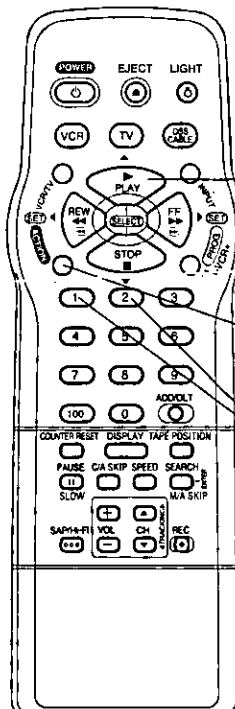
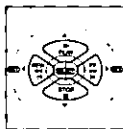

- 2 SELECT/SET
- 3 ▲:PLAY
▼:STOP
▶:FF
- 4
- 1 ACTION
- 5
- NUMBERED keys

Note

- When using the timer to record two adjacent shows on the same channel, better accuracy can be obtained by programming each shows separately.

ON Timer, VCR Plus+ System, and One Touch recordings are marked automatically.

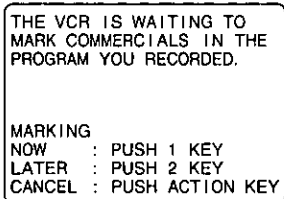

When STOP is pressed during normal recording, Select One of a) or b) or c).

- a) Press 1 key to mark the recording now.
"NOW MARKING COMMERCIALS" appears.
- b) Press 2 key to mark the recording later (after the power has been turned off).
• If the tape is rewound and another recording started before the power is turned off, commercials may not be marked correctly.
- c) Press ACTION to cancel the marking of this recording.

OFF The VCR will not mark commercials.

When you are editing or dubbing a tape, or when you do not wish to use this feature, off should be selected.



Return to normal screen.
Press ACTION three times.

***Important:** If the remote control POWER, ACTION, PROG/VCR+, CH▲ / ▼, NUMBERED keys, INPUT, SEARCH/ M/A SKIP or ADD/HLT button does not work when pressed, press the VCR button on the remote and try the button again.

COMMERCIAL▶▶**ADVANCE**® Playback

When playing back recording which have been marked using **COMMERCIAL▶▶ADVANCE**® feature, you can either set VCR to automatically advance through marked commercial blocks, or set it so that commercials are only skipped on your command.

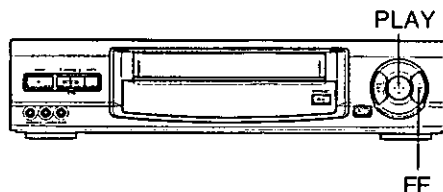

Display MENU.

Press ACTION.*

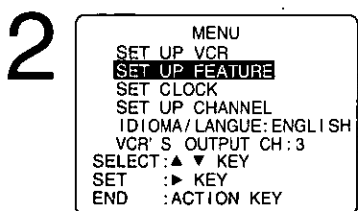

Display SET UP FEATURE.

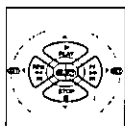

- 1) Press ▲▼ to select.
- 2) Press ► to set.

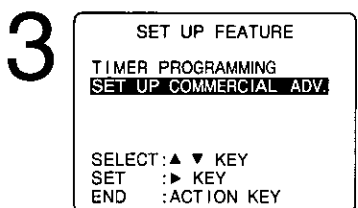

Display SET UP COMMERCIAL ADV.

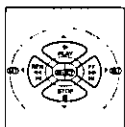

- 1) Press ▲▼ to select.
- 2) Press ► to set.

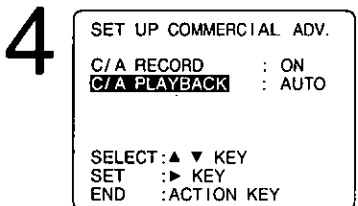

Set AUTO or MANUAL.

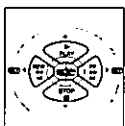

- 1) Press ▲▼ to select.
- 2) Press ► to set.

AUTO VCR will automatically advance through marked commercial blocks recorded on the tape and then resume playback.

MANUAL VCR will advance through commercials only when C/A SKIP is pressed. Playback will resume when the end mark of a commercial block is found, or a new recording or blank portion is detected, or after 8 minutes.

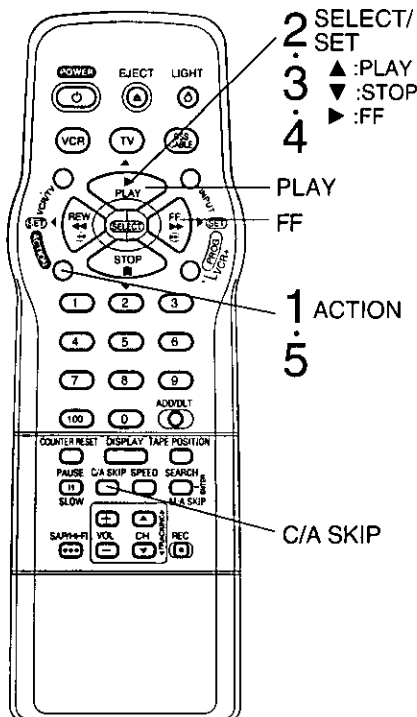

Tape Operation

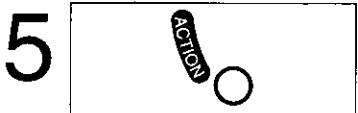

Return to normal screen.

Press ACTION three times.

COMMERCIAL▶▶ADVANCE® is a registered trademark of SRT, Inc.

A Jerry Iggulden invention licensed in association with Arthur D. Little Enterprises, Inc.

U.S. Pat. No. 5,333,091;

5,692,093; 5,696,866

other patents pending

Notes

- The selection mode in step 4 remains set unless there is a power outage in which case the original factory setting will be restored.
- If playback is started in the middle of a commercial, only a single commercial is shown, or an individual commercial is longer than 1 minute, a commercial may not be skipped. Press FF to quickly advance through the commercial.
- Part of a recorded program may be skipped over if the program portion between commercials is less than one minute or there are frequent dark and quiet scenes during the program. To view the portion of tape being incorrectly skipped, press PLAY while the VCR is skipping, reverse the tape to a point just prior to where the skipping began and press PLAY again. This time the group will not be automatically skipped. Automatic skipping will be re-enabled when the end of the marked group is detected.

Tape Operation (continued)

The most commonly asked questions about **COMMERCIAL**ADVANCE*** are answered below.

Question	Answer
How fast does the VCR advance through commercials?	The VCR advances through a 3-minute commercial block in about 8 to 12 seconds if the tape speed is SLP. In SP, it takes about 25 to 35 seconds.
Are commercials advanced through only when I playback a recording?	Yes. The commercials are not marked until after the recording is finished.
Are commercials still recorded on the tape in case I choose to view them sometime?	Yes. By setting the C/A PLAYBACK to MANUAL, see page 23, you can view or advance through commercials as desired.
Does COMMERCIAL**ADVANCE* work in all recording speeds?	Yes. COMMERCIAL**ADVANCE* works in SP, LP, and SLP.
Does the VCR advance through commercials each time I playback tapes which were recorded using COMMERCIAL**ADVANCE* ?	Yes. As long as C/A PLAYBACK is set to AUTO, see page 23, the VCR should advance through commercials each time the tape is played back.
After marking commercials, does the VCR stop at the end of the tape, or rewind to the beginning?	The tape stops at the end of the recording so that any additional timer recordings can be performed.
Can I play my COMMERCIAL**ADVANCE* recordings in non- COMMERCIAL**ADVANCE* VCRs?	Yes. COMMERCIAL**ADVANCE* marked recordings will play in non- COMMERCIAL**ADVANCE* VCRs, but commercials will not be advanced through.
Does the marking process interfere with other programmed recordings?	No. If the interval between 2 or more timer programs is not sufficient to mark the recording, marking will be done after all recordings are complete and the power goes off.
What happens if I cancel the marking in progress so I can use the VCR?	Marking will be resumed when the VCR's power is turned off as long as the tape has not been ejected.
What if part of my program is advanced through along with the commercials?	Please see the 3rd note on page 23.
<p>Additional Notes:</p> <ul style="list-style-type: none"> • Because of the various ways in which commercials are broadcast, the VCR may not be able to recognize all commercials. • If a timer recording is scheduled for the middle of the night, please be aware that the VCR will make some noise as it rewinds and fast forwards the tape while marking commercials. 	

COMMERCIALADVANCE*** is a registered trademark of SRT, Inc.

A Jerry Iggulden invention licensed in association with Arthur D. Little Enterprises, Inc.

U.S.Pat. No. 5,333,091;
5,962,093; 5,696,866
other patents pending

***Important:** If the remote control POWER, ACTION, PROG/VCR+, CH▲ / ▼, NUMBERED keys, INPUT, SEARCH/ M/A SKIP or ADD/HLT button does not work when pressed, press the VCR button on the remote and try the button again.

MOVIE➡ADVANCE®

MOVIE➡ADVANCE® helps you locate certain parts of prerecorded movies (rented or purchased). The feature works in two ways.

- You can go to the beginning of the movie.
- You can skip from one preview to the next.

MOVIE➡ADVANCE® works only on cassette recorded in SP speed with the record tab removed.

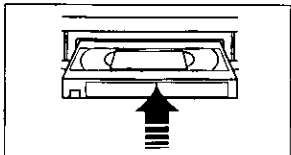
1  **Insert a cassette without record tab.**

2  **Display "SELECT SEARCH MODE."**
1) Press SEARCH/ M/A SKIP.*

- If you inserted a cassette with the record tab or if you selected "INDEX SEARCH" go to page 27.

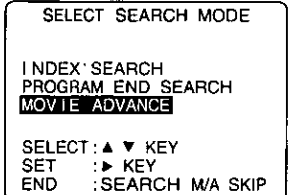
3  **Display MOVIE ADVANCE.**
1) Press ▲▼ to select.
2) Press ► to set.

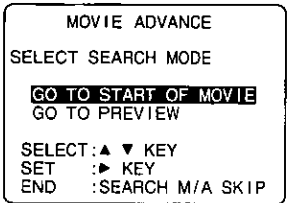
4  **Select GO TO START OF MOVIE or GO TO PREVIEW.**
Press ▲▼ to select.

Select "GO TO START OF MOVIE," if you want to advance directly to beginning of the movie.

--> continue with step 5.

Select "GO TO PREVIEW," if you want to view the first (next) preview.

--> go to "To Search for Preview" at right.

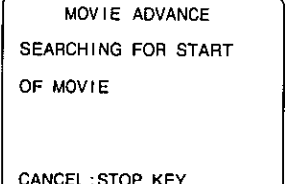
5  **Start searching.**
Press ►.
• To cancel, press STOP.

When the movie is found...

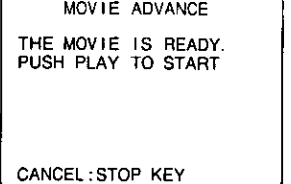
6  **Start playback.**
Press PLAY.
• To cancel, press STOP.
• The display will time out after 3 minutes and the VCR will enter the Stop mode..

Check list before you begin.

- All connections are made.
- One time Setup completed.
- VCR is plugged in.
- TV is turned on and set to CH3, 4 or Video on TV.

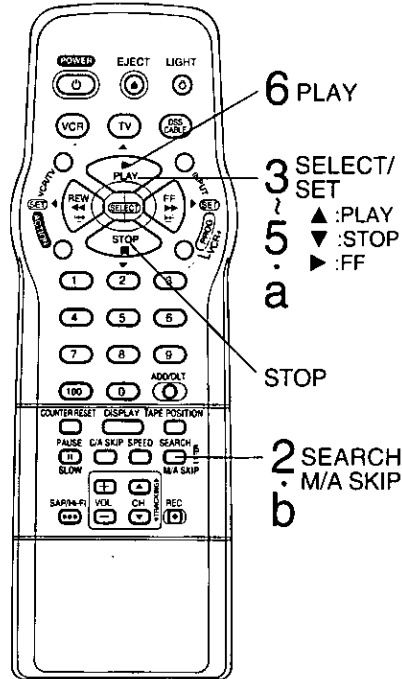

To Search for Preview.

You can override the operation of MOVIE➡ADVANCE® SEARCH FOR PREVIEWS mode by pressing SEARCH/M/A SKIP during tape searching. MOVIE➡ADVANCE® works by searching the tape past each preview and then reversing back to the start of the detected preview. While the tape is reversing back, if SEARCH/ M/A SKIP is pressed, MOVIE➡ADVANCE® will begin searching for the next preview. While searching for the next preview, if you see the start of a preview which you wish to watch, press SEARCH/M/A SKIP and MOVIE➡ADVANCE® will immediately reverse back to the start of that preview, instead of searching further past the preview start point. Once the VCR is playing a preview, press SEARCH/M/A SKIP to advance to the next preview, long commercial or the start of the movie (whichever is next).

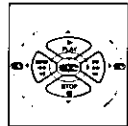
a  **Start preview searching.**
1) In step 4 at left, select GO TO PREVIEW.
2) Press ►.
• If you want to playback, press PLAY.

When a preview is detected, VCR will start playback.

b  **Start next preview searching.**
Press SEARCH/ M/A SKIP.
• To cancel, press STOP.

Tape Operation

Search System

Each time a recording is made, an invisible index mark is placed on the tape. When timer recordings are made, program index and information are also included. These index marks can be used to access or scan recordings.

Program End Search

It is easy to locate the end of a recorded program allowing you to continue recording where you left off.

1



Display SELECT SEARCH MODE in Stop or Play mode.
Press SEARCH/ M/A SKIP.*

2

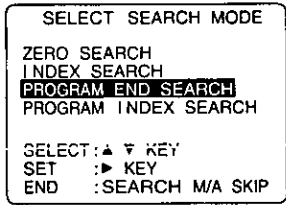

Select PROGRAM END SEARCH.

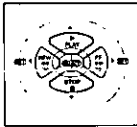

1) Press ▲▼ to select.
2) Press ► to start search.

Examples of Program End Search operation.

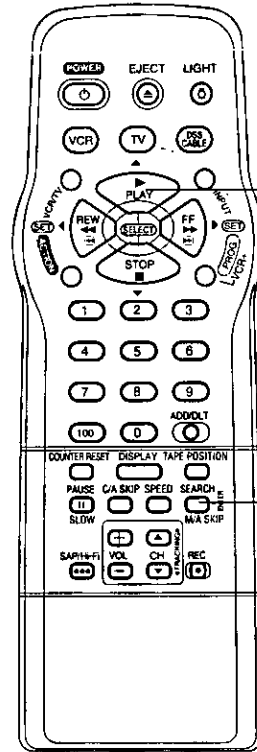
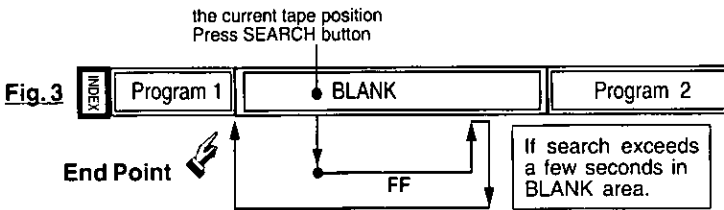
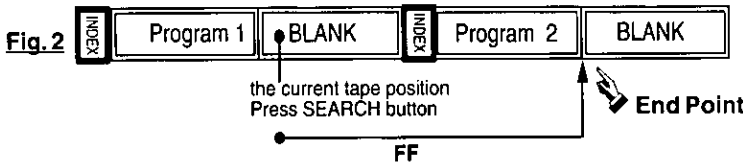
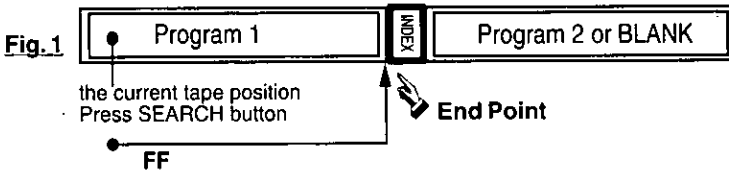

2 SELECT/SET
▲:PLAY
▼:STOP
►:FF

1 SEARCH M/A SKIP

If Program End Point (👉) is found.

The search continues slightly beyond the end point, then search and reverse search and plays the last few seconds of the program and finally stops.

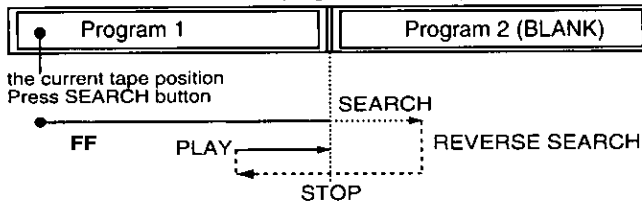

Notes

- If Program End Search is started very close to an index mark, one program may be skipped over.
- To cancel Program End Search, press PLAY or STOP.

***Important:** If the remote control POWER, ACTION, PROG/VCR+, CH▲/▼, NUMBERED keys, INPUT, SEARCH/ M/A SKIP or ADD/HLT button does not work when pressed, press the VCR button on the remote and try the button again.

Program Index Search (For timer recordings only)

Choose a timer recorded program from a Program Index List. When the tape is ejected or normal recording is started, all program index data is deleted.

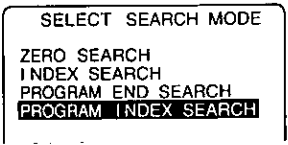
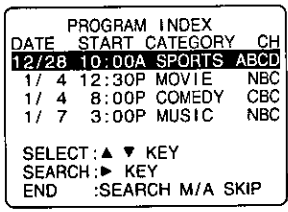
- 1**  **Display SELECT SEARCH MODE** in Stop or Play mode.
Press SEARCH/ M/A SKIP.*
- 2**  **Display PROGRAM INDEX.**
1) Press ▲▼ to select.
2) Press ► to display.
- 3**  **Select the desired recorded program.**
1) Press ▲▼ to select.
2) Press ► to start the forward or rewind search.
• When search is finished, playback begins.

Index Scan (For normal and /or timer recordings)

In Play mode, the first 10 seconds of each recording can be scanned (forward or reverse).

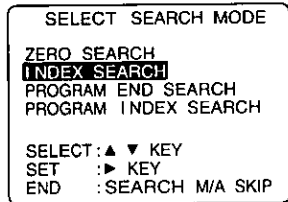
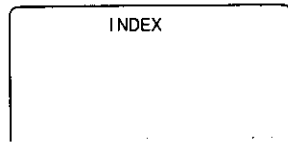
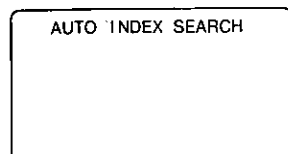
- a**  **Display SELECT SEARCH MODE** in Stop or Play mode.
Press SEARCH/ M/A SKIP.*
- b**  **Select INDEX SEARCH.**
1) Press ▲▼ to select.
2) Press ► to display.
• This screen appears only if there are timer recordings.
- c**  **Start scan.**
Press FF or REW.
- d**  **Cancel scan, start playback.**
Press PLAY.
• To stop, press STOP.

<Example>

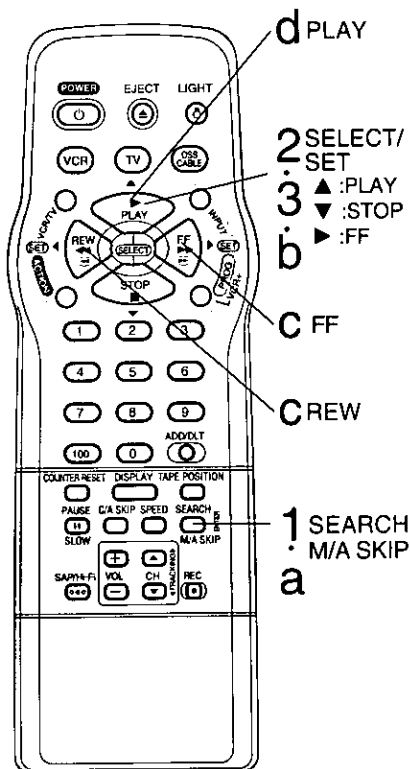
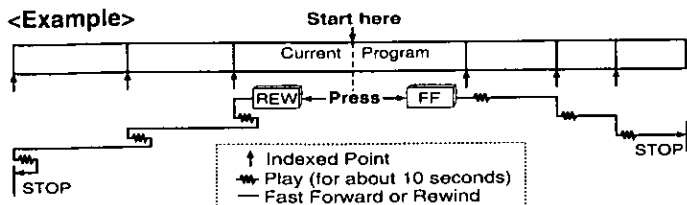

Tape Operation

Auto Operation Functions

■ Auto Playback

insert tape --> Power turns on -->
--> Starts playback if record tab
(see page 40) is removed.

■ Auto Rewind

Playback
Manual Record } --> Tape end -->
Fast Forward } --> Rewinds (Auto)

■ Playback Auto Eject (Repeat Play is "OFF")

Playback --> Tape end --> Rewinds
--> Tape ejects (if without record tab)

■ Memory Rewind Off

Rewind --> Press POWER -->
--> Turns off after completed

Tape Operation (continued)

Direct Access (For normal and /or timer recordings)

Go directly to desired recording.

1  **Display SELECT SEARCH MODE in Stop or Play mode.**
Press SEARCH/ M/A SKIP.*

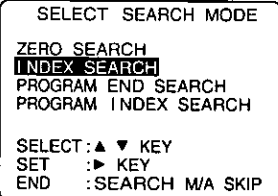
2  **Select INDEX SEARCH.**

- 1) Press ▲▼ to select.
- 2) Press ► to display.

- This screen appears only if there are timer recordings.

3  **Select the recording number.**

Press NUMBERED keys.

- To calculate number, see below.

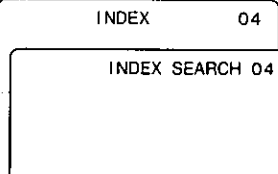
4  **Start search.**

Press FF or REW.

- When search is finished, playback begins.

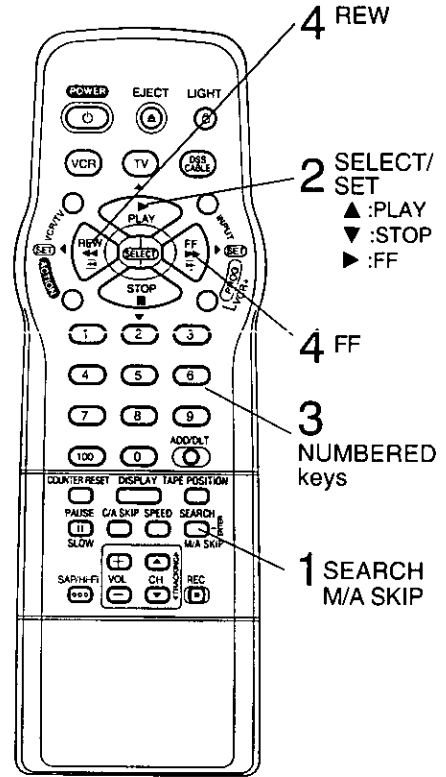

To Calculate Index Number

Example 1:

If you are watching recording 4 and you want to watch recording 2, enter 3 in step "3" and press REW.

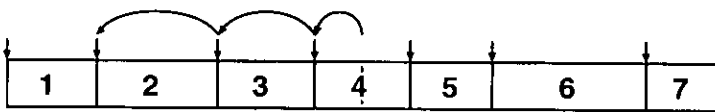

Example 2:

If you are watching recording 2 and you want to watch recording 6, enter 4 in step "3" and press FF.

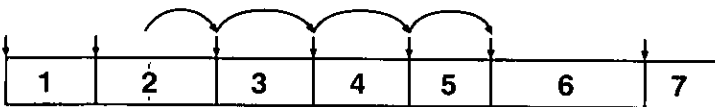

NOTE: ↓ indicates start points of each recording.

Notes

- Make each entry within 10 seconds, or the Index Search mode will be canceled.
- If Direct Access or Index Scan is started very close to an index mark, that index mark may not be counted in the search.

***Important:** If the remote control POWER, ACTION, PROG/VCR+, CH▲/▼, NUMBERED keys, INPUT, SEARCH/ M/A SKIP or ADD/HLT button does not work when pressed, press the VCR button on the remote and try the button again.

Repeat Play

Set to see a recording over and over.



Display MENU.
Press ACTION.*

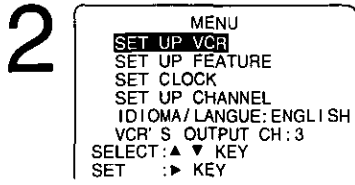

Display SET UP VCR.
1) Press ▲▼ to select.
2) Press ► to display.

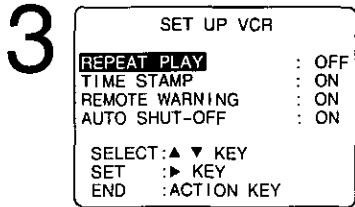

Set ON or OFF.
1) Press ▲▼ to select "REPEAT PLAY."
2) Press ► to set.

- Playback repeats when tape end is reached or unrecorded portion over 30 seconds is detected.

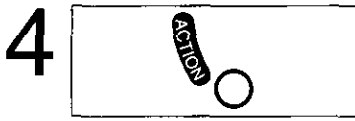

Return to normal screen.
Press ACTION twice.

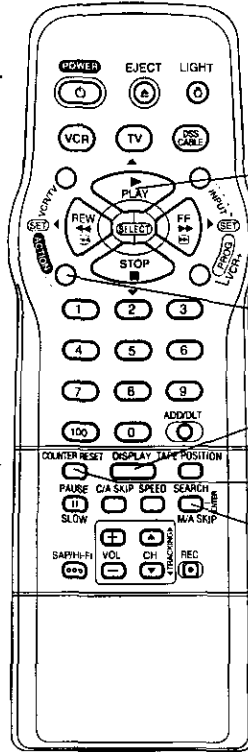

2 SELECT/SET
3 ▲:PLAY
▼:STOP
•:FF

1 ACTION
4

a DISPLAY

b COUNTER RESET

d SEARCH M/A SKIP

Tape Operation

Zero Search

To quickly return to specific tape counter location.

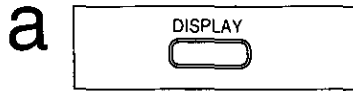

Display Counter.
Press DISPLAY during playback.

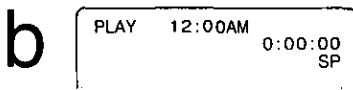

Reset to "0:00:00."
Press COUNTER RESET at the desired position.

c **Continue Recording, playback etc.**

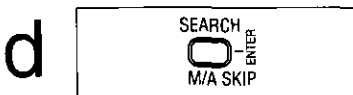

Display SELECT SEARCH MODE in Stop mode.
Press SEARCH/ M/A SKIP.*

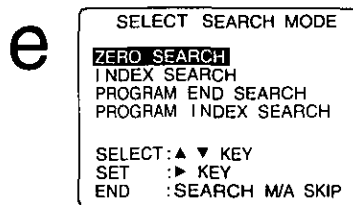

Start ZERO SEARCH.
1) Press ▲▼ to select.
2) Press ► to display.

- Unit will go into FF or REW mode and stop at the last point the Counter was set to 0:00:00.

MTS Broadcast/VHS Hi-Fi Stereo System

- Check list before you begin.
- VCR is connected to a stereo TV, or a mono TV and an external stereo amp or receiver with speakers.
- VCR and other components are plugged in and turned on.

Connections to Make

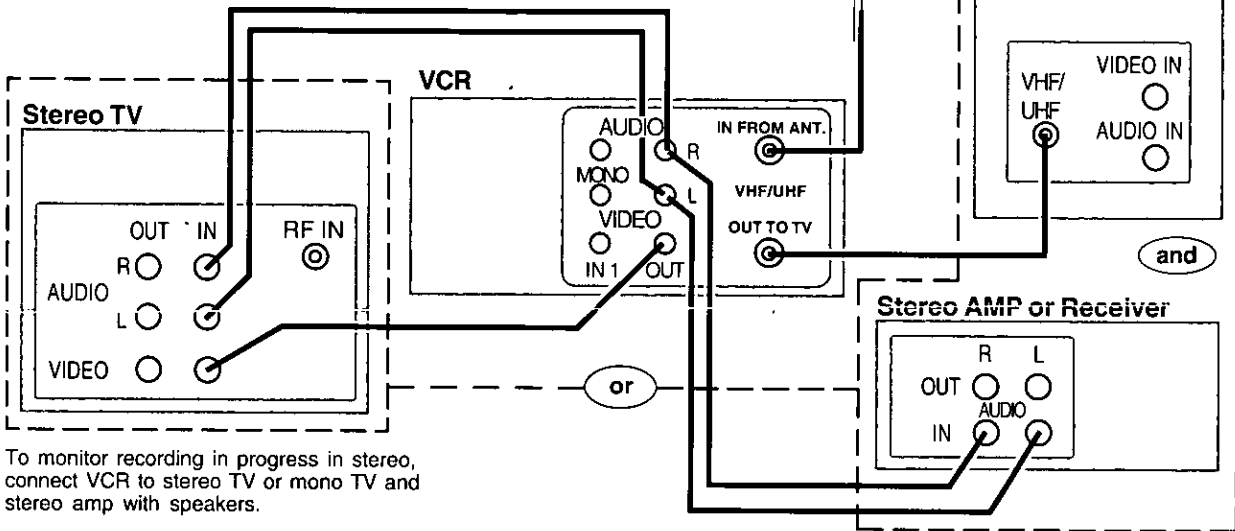

To monitor recording in progress in stereo, connect VCR to stereo TV or mono TV and stereo amp with speakers.

Receivable Broadcast Types

The following are possible audio broadcast types and on-screen displays. The signal being received is indicated with an "α" mark while the selected audio mode is indicated with an arrow.

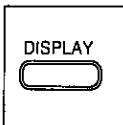

Display the broadcast signal being received. Press DISPLAY.

MTS Stereo and SAP broadcast

Multi-channel Television Sound Stereo (main language) and Secondary Audio Program (sub language) broadcasts are both being received simultaneously. Select STEREO or SAP audio mode.

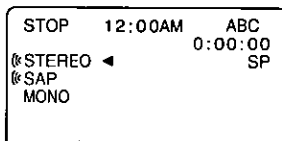

MTS Stereo broadcast

Multi-channel Television Sound Stereo broadcast. Select STEREO audio mode.

- If stereo broadcast is weak and display flickers, select MONO audio mode for possibly better results.

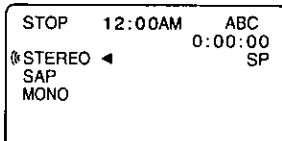

SAP broadcast

Secondary Audio Program (sub language) broadcast. Select SAP audio mode for the sub language.

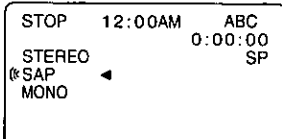

MONO broadcast

Normal monaural sound broadcast.

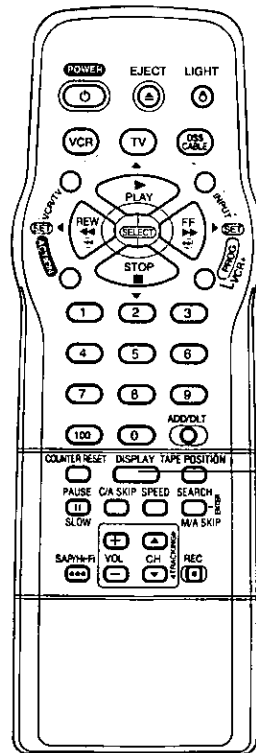
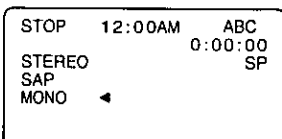

DISPLAY

Equipped with **dbx**®-TV Noise Reduction for true MTS reproduction. **dbx**®-TV Noise Reduction is required for good stereo separation and audio fidelity. **dbx**® is a registered trademark, and is licensed by **dbx**® Technology Licensing.

When set to proper audio mode VCR can:

- 1) record/playback MTS stereo broadcasts (main language) in Hi-Fi stereo.
- 2) record/playback mono (main language) or SAP (sub language) broadcasts.
- 3) playback non Hi-Fi tapes in monaural.

- The selected broadcast sound is always recorded on left and right Hi-Fi track as well as the normal monaural track. This means tapes can be played back on Hi-Fi and non-Hi-Fi VCRs.

Audio Mode for Recording

1  **Display audio mode.**
Press SAP/ Hi-Fi.

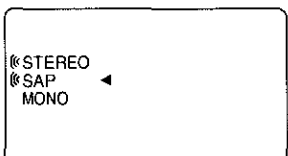
2  **Select desired mode.**
Press SAP/ Hi-Fi repeatedly (each press within 5 seconds).

- Arrow indicates selection.
- Refer to the "Receivable Broadcast Types" on page 30.

3 **Do a recording.**
See page 9.

Audio Mode for Playback

a **Start playback.**
See page 8.

b  **Display audio mode.**
Press SAP/ Hi-Fi.

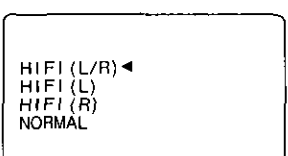
c  **Select desired mode.**
Press SAP/ Hi-Fi repeatedly (each press within 5 seconds).

- Arrow indicates selection.
- Select "HIFI(L/R)" or "HIFI(L)" or "HIFI(R)" to listen to stereo recordings in stereo sound. Select "NORMAL" for monaural sound.

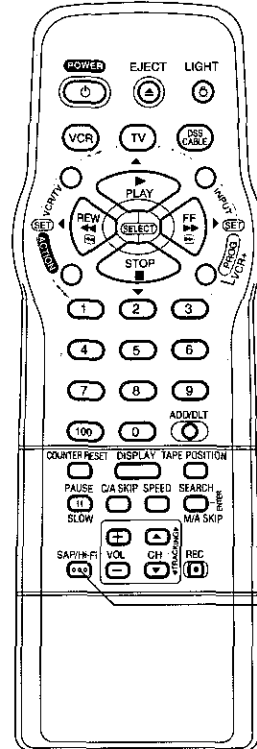

1. SAP/
Hi-Fi
2.
b.
c.

Notes

- Only tapes recorded in Hi-Fi stereo will play back with true stereo sound. Standard stereo tapes will playback in monaural sound.
- To listen to Hi-Fi stereo playback, the VCR AUDIO (L/R) jacks must be connected to a stereo TV or an external stereo amp and speakers. (See page 30.)
- If tracking is adjusted during playback, Hi-Fi audio may revert to normal audio.
- Hi-Fi and normal audio playback volume level may differ.

Special VCR Features

Channel Caption

When set, station name, e.g. ABC, CBS, and channel number appear on-screen.
Set up to 24 preset captions, and/or 10 manually created captions.

You need a list of stations and the channel numbers you receive them on.

Preset Caption

1  **Display MENU.**
Press ACTION.*

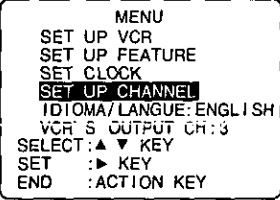
2  **Display SET UP CHANNEL.**
1) Press ▲▼ to select.
2) Press ► to display.

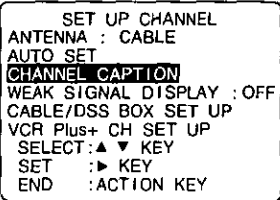
3  **Display CHANNEL CAPTION.**
1) Press ▲▼ to select.
2) Press ► to display.

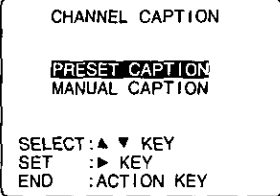
4  **Display PRESET CAPTION.**
1) Press ▲▼ to select.
2) Press ► to display.
• To create your own captions, go to "Manual Caption" on page 33.

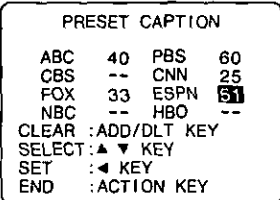
5  **Assign preset captions.**
1) Press ▲▼ to highlight caption.
2) Press ► to move cursor to the right.
3) Press ▲▼ to select CH number.
4) Press ◀ to set.

• Repeat step 5 until the list is complete.

To make corrections,
Press ▲▼ and ► to select the channel number, then press ▲▼ to change, or ADD/DLT to delete the number.

6  **End setup.**
Press ACTION four times.

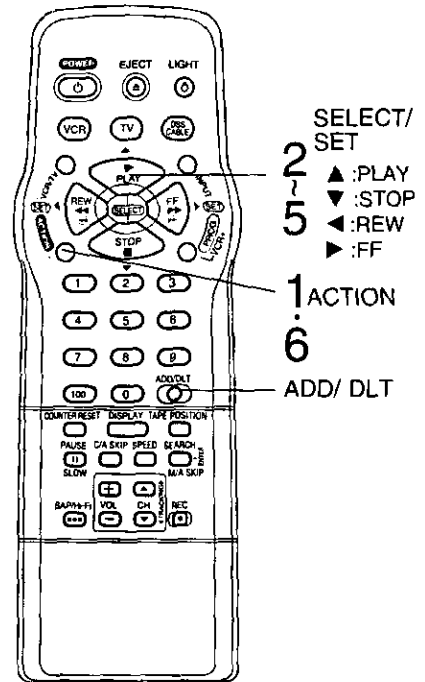

***Important:** If the remote control POWER, ACTION, PROG/VCR+, CH▲/▼, NUMBERED keys, INPUT, SEARCH/ M/A SKIP or ADD/DLT button does not work when pressed, press the VCR button on the remote and try the button again.

Manual Caption

1 Do "Preset Caption" steps 1~3 on page 32.

2

CHANNEL CAPTION

PRESET CAPTION
MANUAL CAPTION

SELECT:▲ ▼ KEY
SET :▶ KEY
END :ACTION KEY

Display MANUAL CAPTION.

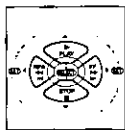

- 1) Press ▲▼ to select.
- 2) Press ▶ to display.

3

MANUAL CAPTION

CH NUMBER CAPTION

02 ---

SELECT:▲ ▼ KEY
SET :▶ KEY
END :ACTION KEY

Select channel number.

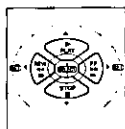

- 1) Press ▲▼ to select CH NUMBER.
- 2) Press ▶ to move cursor to the right.

- Channels already set and channels deleted from Channel Memory are not displayed.
- You can set a total of ten channel captions.

4

MANUAL CAPTION

CH NUMBER CAPTION

02 A---

CLEAR :ADD/DLT KEY
SELECT:▲ ▼ KEY
SET :◀▶ KEY

Enter CAPTION.

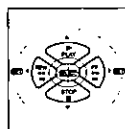

- 1) Press ▲▼ to select.
 - 2) Press ▶ to enter.
- Characters change in following order.

A ↔ B ↔ C ↔ ... ↔ Z ↔ BLANK ↔ - ↔ & ↔
9 ↔ 8 ↔ 7 ↔ 6 ↔ 5 ↔ 4 ↔ 3 ↔ 2 ↔ 1 ↔ 0 ↔ / ↔ ! ↔

- 3) Press ◀ to set.

- Repeat steps 3 and 4 as desired.

To make corrections,

Press ◀▶ to move to the incorrect entry, then press ▲▼ to make correction. Or, press ADD/DLT to clear the caption.

5

End input.

Press ACTION four times.

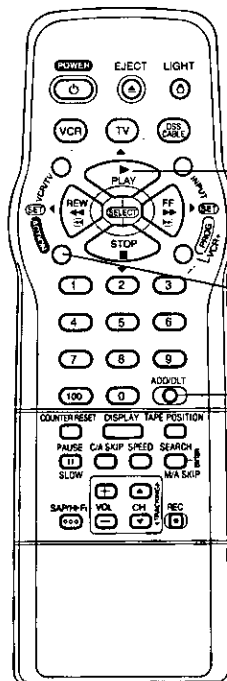

- 2 SELECT/SET
 - 3 ▲:PLAY
▼:STOP
 - 4 ◀:REW
▶:FF
 - 5 ACTION
- ADD/ DLT

Special VCR Features

Special VCR Features (continued)

Time Stamp Feature

The VCR writes program data (see example below) about the first 10 seconds of every recording. The information is then displayed the first 10 seconds of playback. To change the data, see "Changing Time Stamp Data" on page 35.

- Check list before you begin.
- Clock is set to correct time.
- Record tab in place. (See page 40.)



Display MENU.
Press ACTION.*

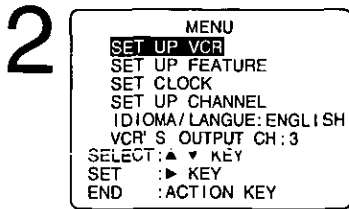

Display SET UP VCR.

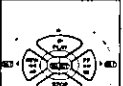

1) Press ▲▼ to select.
2) Press ► to display.

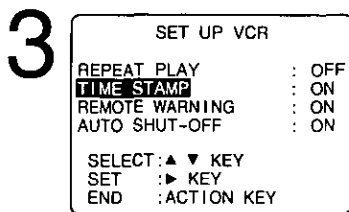

Set ON or OFF.

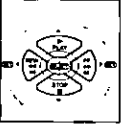

1) Press ▲▼ to select.
2) Press ► to set.

- When "OFF" is selected, the program data is written on the tape, but will not be displayed.



Return to normal screen.
Press ACTION twice.

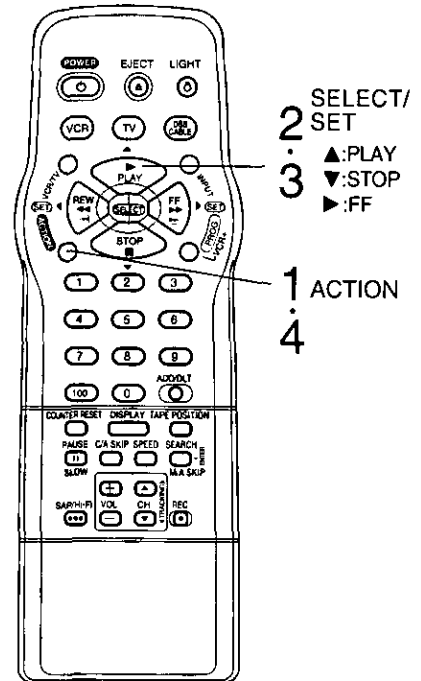

<Time Stamp Example>

One Touch Recording

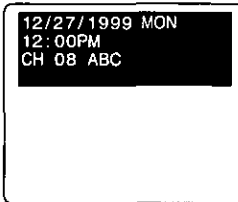

Timer Recording

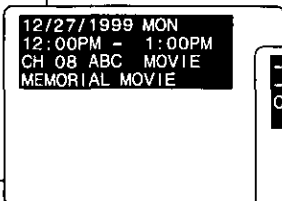

When Clock is not set...

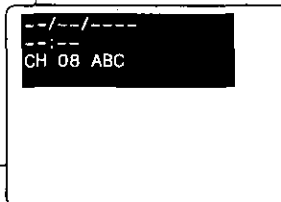

***Important:** If the remote control POWER, ACTION, PROG/VCR+, CH▲/▼, NUMBERED keys, INPUT, SEARCH/ M/A SKIP or ADD/HLT button does not work when pressed, press the VCR button on the remote and try the button again.

Changing Time Stamp Data

You may change the Date, Time, Channel, Category, and Notes.

1



Display Time Stamp Data.

- 1) Insert cassette with record tab.
- 2) Press PLAY.

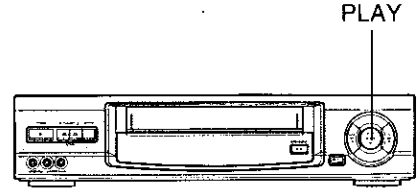

2

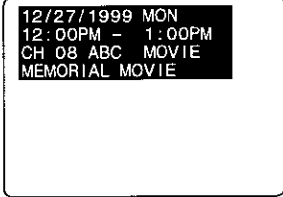

Display TIME STAMP EDIT.

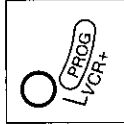

Press PROG/VCR+ while the data is displayed in Playback mode.

3

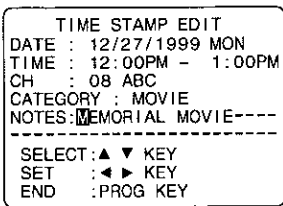

Change Time Stamp Data.

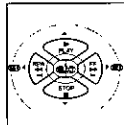

- 1) Press ▲▼ to select.
- 2) Press ► to enter and continue.

• Characters in NOTES will change in the following order.

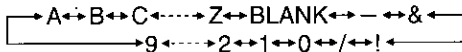

- 3) Repeat 1) and 2) as needed.

To make corrections,

Press ◀▶ to move to the incorrect entry, then press ▲▼ to make the correction.

4

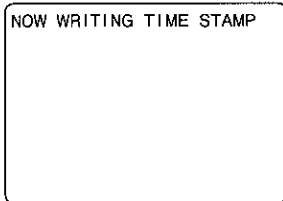

Write the new data.

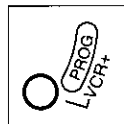

Press PROG/VCR+.

- When data is written, VCR returns to Stop mode.

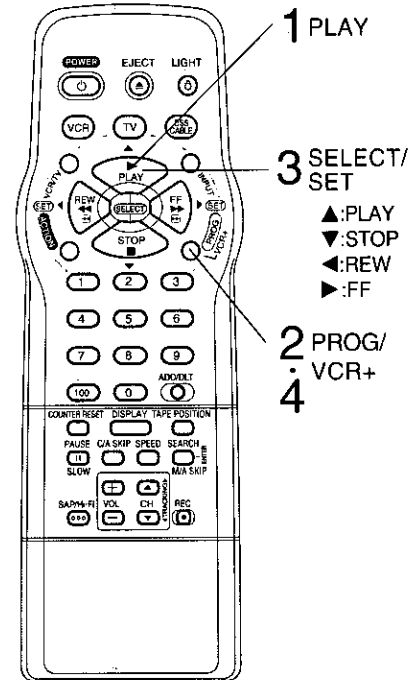

Special VCR Features

Special VCR Features

Tape Position Display Feature

To find out the present tape position.

Tape position cannot be found for C-Cassette type and tape of less than 60 minutes.



Detect Tape Position.
Press TAPE POSITION.

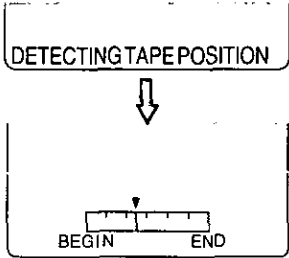

- "DETECTING TAPE POSITION" only appears the first time a cassette is inserted.
- It takes several seconds for correct indication to appear.

• The present tape position indication is displayed.



Return to normal screen.
Press TAPE POSITION.

Remote Warning ON/OFF Feature

If Multi-brand feature is used (page 20), and this feature is set to on, a warning appears whenever an invalid key is pressed in TV, DSS, or Cable mode.



Display MENU.
Press ACTION.

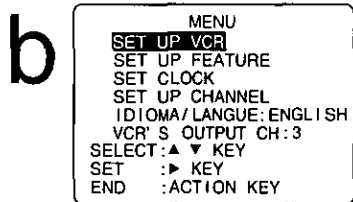

Display SET UP VCR.

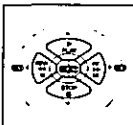

- 1) Press ▲▼ to select.
- 2) Press ► to display.

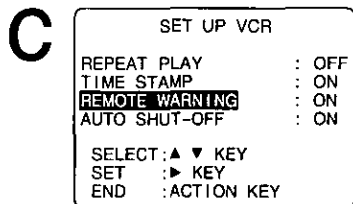

Set ON or OFF.

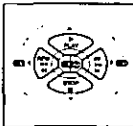

- 1) Press ▲▼ to select.
- 2) Press ► to set.

• "OFF" --> remote warning will not appear even if invalid key is pressed.



Return to normal screen.
Press ACTION twice.

Check list before you begin.

- All connections are made. (See pages 4-5.)
- VCR is plugged in.
- TV is turned on and tuned to CH3, 4 or Video.

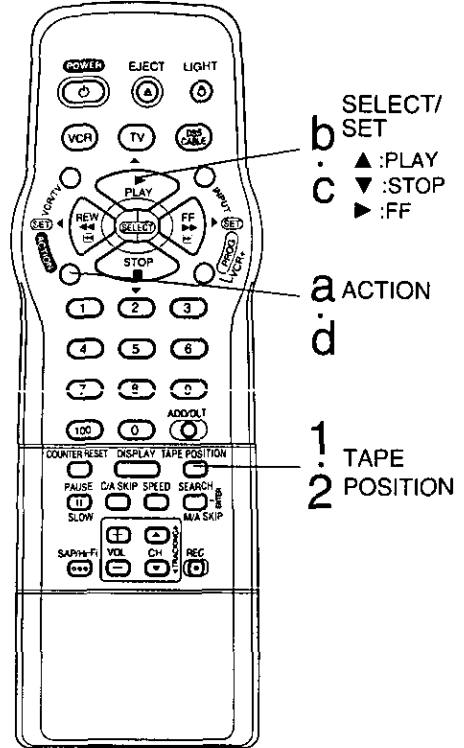

b SELECT/SET

- ▲ :PLAY
- ▼ :STOP
- :FF

a ACTION

d

- 1 TAPE POSITION
- 2 TAPE POSITION

VCR Lock Feature

All operations are prohibited except timer recording and tape eject. Useful for families with small children.



Press REC in Stop mode.

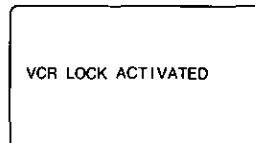

To turn on:
In Stop mode, hold down REC on the VCR without a cassette inserted for 7 seconds.

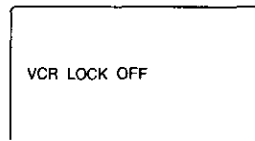

To turn off:
Repeat above.

- VCR Lock is canceled automatically after 24 hours if clock is set.

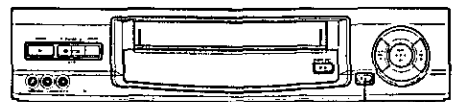

A REC

***Important:** If the remote control POWER, ACTION, PROG/VCR+, CH▲/▼, NUMBERED keys, INPUT, SEARCH/ M/A SKIP or ADD/HLT button does not work when pressed, press the VCR button on the remote and try the button again.

Weak Signal Display ON/OFF Feature

When "ON" is selected, picture is displayed even when broadcast signal is weak or nonexistent.



Display MENU.
Press ACTION.*

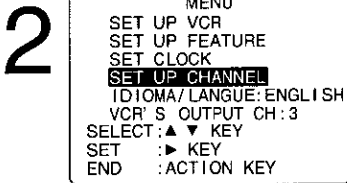

Display SET UP CHANNEL.

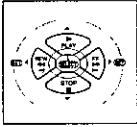

1) Press ▲▼ to select.
2) Press ► to display.

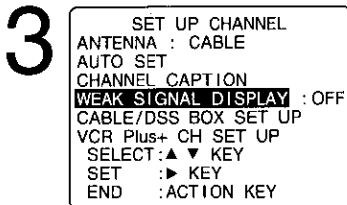

Set ON or OFF.

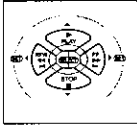

1) Press ▲▼ to select.
2) Press ► to set.

- ON --> Picture is displayed regardless of signal condition, and may not always be clearly visible.
- OFF --> Screen turns solid blue when signal is absent or weak.
- If VCR is connected to equipment which has blue back feature, selecting ON will have no effect on the other equipment.



Return to normal screen.
Press ACTION twice.

Auto Shut-Off Feature

When "ON" is selected, VCR shuts itself off when playback of a blank portion of tape continues or no signal (except when LINE is selected) is detected for over 5 minutes.

a Repeat step "a" and "b" on page 36 to display SET UP VCR.

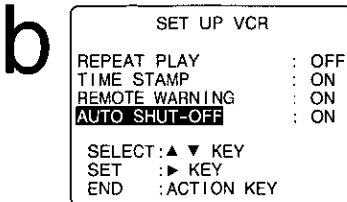

Set ON or OFF.

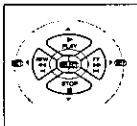

1) Press ▲▼ to select.
2) Press ► to set.



Return to normal screen.
Press ACTION twice.

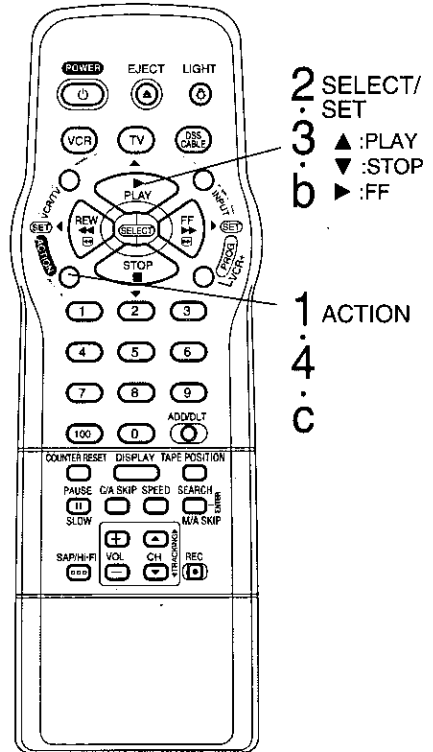

Special VCR Features

Reset Language, Channels, Clock, VCR's

1

```

MENU
SET UP VCR
SET UP FEATURE
SET CLOCK
SET UP CHANNEL
IDIOMA/LANGUE: ENGLISH
VCR'S OUTPUT CH: 3
SELECT: ▲ ▼ KEY
SET : ► KEY
END : ACTION KEY
    
```



Display MENU.
Press ACTION.*

2 ■ Language

1) Press ▲▼ to highlight language item.

```

MENU
SET UP VCR
SET UP FEATURE
SET CLOCK
SET UP CHANNEL
IDIOMA/LANGUE: ENGLISH
VCR'S OUTPUT CH: 3
SELECT: ▲ ▼ KEY
SET : ► KEY
END : ACTION KEY
    
```

2) Press ► repeatedly.

```

MENU
SET UP VCR
SET UP FEATURE
SET CLOCK
SET UP CHANNEL
IDIOMA/LANGUE: ENGLISH
VCR'S OUTPUT CH: 3
SELECT: ▲ ▼ KEY
SET : ► KEY
END : ACTION KEY
    
```

For English

```

MENU
PREPARAR VCR
FIJACION DE FUNCIONES
FIJAR RELOJ
FIJAR CANAL
LANGUE/LANGUAGE: ESPAÑOL
SALIDA DE VCR CANAL: 3
ELEGIR: ▲ ▼
FIJAR : ►
TERMINAR: ACTION
    
```

For Spanish

```

MENU
REGLAGE MAGNETOSCOPE
REGLAGE MAGNETO SUPPLEM
REGLAGE HORLOGE
REGLAGE CANAL
LANGUAGE/IDIOMA: FRANÇAIS
CA SORTIE: 3
SEL. : ▲ ▼
REGLER: ►
FIN : ACTION
    
```

For French

■ Channels

1) Press ▲▼ to select SET UP CHANNEL.

```

MENU
SET UP VCR
SET UP FEATURE
SET CLOCK
SET UP CHANNEL
IDIOMA/LANGUE: ENGLISH
VCR'S OUTPUT CH: 3
SELECT: ▲ ▼ KEY
SET : ► KEY
END : ACTION KEY
    
```

2) Press ►.

```

SET UP CHANNEL
ANTENNA : CABLE
AUTO SET
CHANNEL CAPTION
WEAK SIGNAL DISPLAY : OFF
CABLE/DSS BOX SET UP
VCR Plus+ CH SET UP
SELECT: ▲ ▼ KEY
SET : ► KEY
END : ACTION KEY
    
```

3) Press ▲▼ to select "ANTENNA," then press ► to set your antenna system (TV or CABLE).

4) Press ▲▼ to select "AUTO SET," then press ►.

• If you use a cable box, set it to the PBS channel in your time zone.

```

CHANNEL/CLOCK AUTO SET
CONNECT ANTENNA CABLE
AND IF YOU USE A CABLE
BOX, TUNE IT TO YOUR
LOCAL PBS CH THEN...

PLEASE PUSH CH UP KEY
    
```

(This screen appears only when auto clock is set.)

5) Press CH ▲.

• Clock Auto Set will be performed when channels are replaced in memory.

■ Clock

1) Press ▲▼ to select SET CLOCK.

```

MENU
SET UP VCR
SET UP FEATURE
SET CLOCK
SET UP CHANNEL
IDIOMA/LANGUE: ENGLISH
VCR'S OUTPUT CH: 3
SELECT: ▲ ▼ KEY
SET : ► KEY
END : ACTION KEY
    
```

2) Press ►.

```

SET CLOCK

AUTO CLOCK SET
MANUAL
TIME ZONE ADJUST : 0

SELECT: ▲ ▼ KEY
SET : ► KEY
END : ACTION KEY
    
```

("TIME ZONE ADJUST" appears only when clock is set automatically.)

3) Press ▲▼ to select MANUAL and press ►.

• For Auto Clock Set, select "AUTO CLOCK SET," then press CH ▲.

```

SET CLOCK 1/ 1/
1/ 4/2000 TUE 12:00PM
DST: ON
-----
SELECT HOUR

SELECT: ▲ ▼ KEY
SET : ◀ ▶ KEY
END : ACTION KEY
    
```

4) Press ▲▼ and ◀▶ to select and set the date, time, and DST (Daylight Saving Time).

5) Press ACTION twice to start the clock and exit this mode.

Output Channel

***Important:** If the remote control POWER, ACTION, PROG/VCR+, CH▲/▼, NUMBERED keys, INPUT, SEARCH/ M/A SKIP or ADD/HLT button does not work when pressed, press the VCR button on the remote and try the button again.

Time Zone Adjust

(When Auto Clock is set only.)

- 1) Press ▲▼ to select SET CLOCK.

```

MENU
SET UP VCR
SET UP FEATURE
SET CLOCK
SET UP CHANNEL
IDIOMA/ LANGUE: ENGLISH
VCR' S OUTPUT CH: 3
SELECT: ▲ ▼ KEY
SET : ► KEY
END : ACTION KEY
    
```

- 2) Press ►.

```

SET CLOCK

AUTO CLOCK SET
MANUAL
TIME ZONE ADJUST : 0

SELECT: ▲ ▼ KEY
SET : ◀ ▶ KEY
END : ACTION KEY
    
```

- 3) Press ▲▼ to select TIME ZONE ADJUST and press ◀ or ▶ to subtract or add hour(s) as necessary.

```

SET CLOCK

AUTO CLOCK SET
MANUAL
TIME ZONE ADJUST : +1

SELECT: ▲ ▼ KEY
SET : ◀ KEY
END : ACTION KEY
    
```

- 4) Press ACTION twice.

- 5) Press POWER off to perform AUTO CLOCK SET.

- TIME ZONE ADJUST returns to "0" if clock is set manually.

VCR's Output Channel

- 1) Press ▲▼ to select VCR'S OUTPUT CH.

```

MENU
SET UP VCR
SET UP FEATURE
SET CLOCK
SET UP CHANNEL
IDIOMA/ LANGUE: ENGLISH
VCR' S OUTPUT CH: 3
SELECT: ▲ ▼ KEY
SET : ► KEY
END : ACTION KEY
    
```

- 2) Press ►.

```

IF YOU PUSH ACTION KEY,
VCR' S OUTPUT CH SWITCHES
TO CH 4.
    
```

- 3) Press ACTION.

```

PLEASE TUNE YOUR TV TO
CH 4.
    
```

After 3 seconds

```

MENU
SET UP VCR
SET UP FEATURE
SET CLOCK
SET UP CHANNEL
IDIOMA/ LANGUE: ENGLISH
VCR' S OUTPUT CH: 4
SELECT: ▲ ▼ KEY
SET : ► KEY
END : ACTION KEY
    
```

- To Make Corrections, repeat step 1) ~ 3).

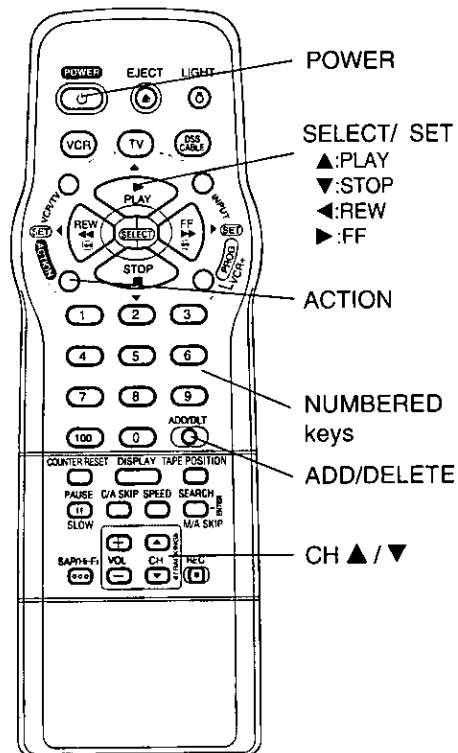

Add or Delete a Channel

To add channel:
Select channel with NUMBERED keys and press ADD/HLT.

```

CHANNEL 08 ADDED
    
```

To delete channel:
Select channel with CH ▲ / ▼ or NUMBERED keys and press ADD/HLT.

```

CHANNEL 08 DELETED
    
```

Reset Language, Channel, Clock

VCR & Cassette Information

Reset All VCR Memory Functions

Use when moving VCR to new location, or if a mistake was made in the One Time VCR Setup section.

- Make sure a tape is not inserted in the VCR.

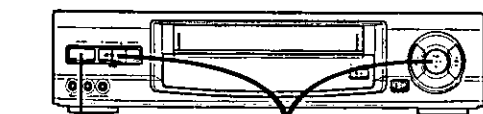

1 Turn VCR Power on.

2 Press and hold both **PLAY** and **CHANNEL ▲** on the VCR for more than 5 seconds.

- The power will shut off.

3 Do "One Time VCR Setup" steps on page 6.

Prevent Accidental Tape Erasure

Break off the tab.

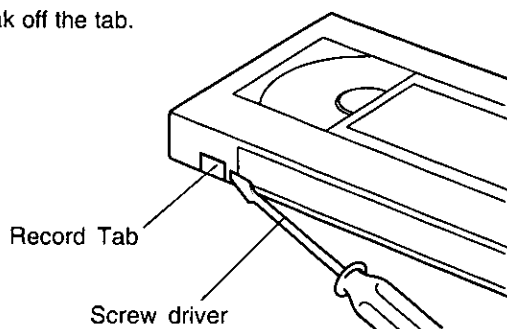

To record again

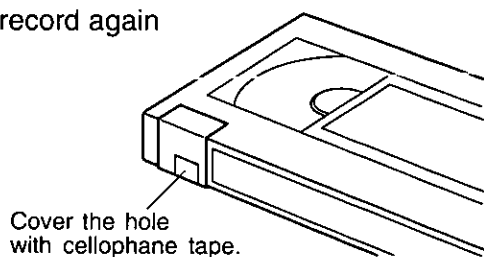

DST (Daylight Saving Time)

VCR auto adjusts clock for DST. (Page 7.)

Spring (First Sunday in April)

DST:ON --> sets clock ahead one hour.

Autumn (Last Sunday in October)

DST:ON --> Turns clock back one hour.

- If your area does not observe Daylight Saving Time, select DST:OFF.
- Keep these time changes in mind when programming the VCR for timer recordings.

Record/Playback Time

Only use tapes with the **VHS** mark in this unit.

Tape Speed Setting	Type of Video Cassette		
	T60	T120	T160
SP (Standard Play)	1 Hour	2 Hours	2 Hours 40 Minutes
LP (Long Play)	2 Hours	4 Hours	5Hours 20 Minutes
SLP (Super Long Play)	3 Hours	6 Hours	8 Hours

Head Cleaning

Playing older or damaged tapes may eventually cause video heads to become clogged.

Video Head Clog Sensor

During playback this screen appears if clogging is detected. To remove screen, press PLAY on the remote or VCR.

VIDEO HEADS MAY
NEED CLEANING
PLEASE INSERT HEAD
CLEANING CASSETTE
OR REFER TO MANUAL

END:PLAY KEY

- Use "dry" type head cleaning cassette only. (Part No. NV-TCL30PT is recommended.)

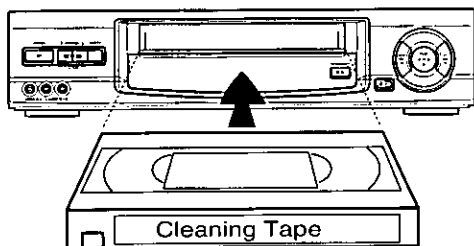

- Follow cleaning tape instructions carefully. Excessive use of tape can shorten head life.
- If head clog symptoms persist, contact your nearest Factory Service Center or authorized Service Center. (See page 45.)

Built-in Head Cleaner

A clean video head helps produce a clear picture.

So, we have equipped your VCR with a built-in, non-chemical head cleaning system that helps prevent clogging of the video heads. Cleaning is performed each time you load or unload a video cassette.

- This feature is preventative only. If your video heads are seriously clogged, consider the use of a chemical non-abrasive head cleaning kit or take your VCR to a Service Center.

Cleaning the VCR

Use a soft cloth or dusting attachment of your vacuum cleaner to dust your VCR. Remove dust from the ventilation holes on the back sides and bottom of the cabinet.

Plastic surfaces are easily scratched and can be marred by alcohol and various solvents. Avoid excessive use of oil-based furniture polishes since the materials used in the cabinet will accumulate more dust. We recommend using a nonabrasive, antistatic cleaner and polisher.

Specifications

Power Source:	120 V AC, 60 Hz
Power Consumption:	Power On Approx. 23 watts Power Off Approx. 3.3 watts
Video Signal:	EIA Standard NTSC color
Video Recording System:	4 rotary heads helical scanning system
Audio Track:	1 track (Normal) 2 channel (Hi-Fi Audio Sound)
Tuner:	
Broadcast Channels:	VHF 2~13, UHF 14~69
CABLE Channels:	Midband A through I (14~22) Superband J through W (23~36) Hyperband AA~EEE (37~64) Lowband A-5~A-1 (95~99) Special CABLE channel 5 A (01) Ultraband 65~94, 100~125
Operating Temperature:	5 °C~40 °C (41 °F~104 °F)
Operating Humidity:	10 %~75 %
Weight:	3.4 kg (7.4 lbs.)
Dimensions:	430 (W) x 98 (H) x 250 (D) mm 16-15/16" (W) x 3-7/8" (H) x 9-3/4" (D)

Note: Designs and specifications are subject to change without notice.

Features for a Quality Picture

Digital Auto Picture

Automatically controls the video output signal for less noise depending on the tape condition.

Digital Auto Tracking

Continuously analyzes the signal and adjusts for optimum picture quality.

Manual Tracking Control (to reduce picture noise)

Use during Playback and Slow Motion mode to reduce picture noise. Press CH (TRACKING) ▲ / ▼ buttons on the remote control or on the VCR until the picture clears up. To return to Auto Tracking, press POWER off, then on again a few seconds later.

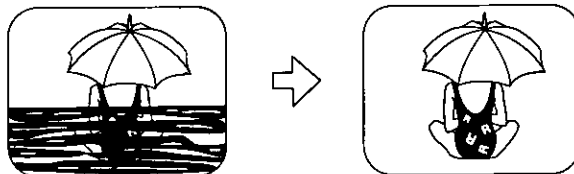

V-Lock Control (to reduce picture jitter)

In Still mode, CH (TRACKING) ▲ / ▼ buttons operate as a V-Lock control.

On-Screen Displays (OSD)

Function & Channel Display

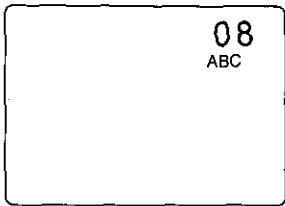

When a function button is pressed, e.g. PLAY, or you change channels, a 4 second display appears first in large and then small characters. (Some Station names may also appear if Channel Caption is set. See page 32, 33.)

VCR Status & Clock Display

To display or remove the overlay.

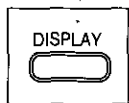

Press DISPLAY.

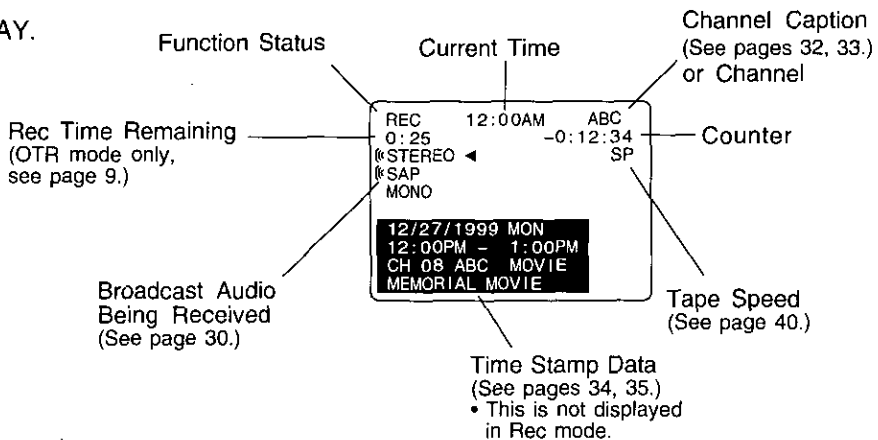

Blank Tape/ No Video Signal Indication

Whenever a blank section of a tape comes up in Play mode, or when the selected channel has no broadcast signal with the Weak Signal Display Feature (page 37) set to OFF, the TV screen will turn solid blue.

Warning and Instruction Displays

These displays will alert you of a missed operation or provide further instructions.

OSD	Caution	Pg	OSD	Caution	Pg
NO CH FOUND PLEASE CHECK ANTENNA CABLE CONNECTION THEN PUSH VCR CH UP KEY AGAIN	If no active channels are found for CHANNEL MEMORY...	6	TO CANCEL TIMER REC PUSH POWER THEN STOP KEY	If you press POWER or STOP during a Timer Recording... (visible in VCR mode only)	13
PLEASE SET CLOCK BEFORE PROGRAMMING	If you attempt to set or review a Timer Recording and the Clock is not set...	12	VIDEO HEADS MAY NEED CLEANING PLEASE INSERT HEAD CLEANING CASSETTE OR REFER TO MANUAL END: PLAY KEY	If head cleaning becomes necessary while playing back a tape...	41
TURN VCR OFF FOR TIMER RECORDING	After a Timer Program has been set...	13	VCR LOCK ACTIVATED	If you press a function button other than STOP/EJECT or POWER while the VCR is in VCR Lock mode...	36
CHECK CASSETTE RECORD TAB	If you press REC on the remote control or VCR, and a cassette is inserted with no record tab...	40	REMOTE CONTROL IS SET TO CABLE/DSS MODE USE VCR : VCR KEY USE TV : TV KEY	If you press any invalid keys on the remote while in CABLE/DSS mode...	20 21 36
NO CASSETTE PLEASE INSERT A CASSETTE	If you press PLAY, FF, REW, or REC on the remote control or VCR without a cassette inserted...	8 9	REMOTE CONTROL IS SET TO TV MODE USE VCR : VCR KEY USE CABLE/DSS : CABLE/DSS	If you press any invalid keys on the remote while in TV mode...	20 21 36

Before Requesting Service

Check the following points once again if you are having trouble with your VCR.

Power	Correction
No power...	<ul style="list-style-type: none"> • Completely insert Power Plug into an AC outlet. • Set POWER button to on. • Make sure power source is active.
Recording & Playback	Correction
TV program cannot be recorded...	<ul style="list-style-type: none"> • Check connections between VCR, external antenna, and TV. • Check hook up selection. (P.4-5) • Make sure your antenna system (CABLE or TV) is correctly set. (Channels [P.38]) • Make sure cassette record tab is intact. (P.40)
Timer recording cannot be performed...	<ul style="list-style-type: none"> • Check clock is set to current time and date. • Make sure Cable/DSS box (if used) is left on and tuned to channel to be recorded. • Set recording start/stop times correctly. (P.12) • Make sure POWER button is set to off. (P.12, 13) • Timer recording may not be performed or continued if a power interruption of more than 1 minute occurs before or during, a Timer Recording, even after power is restored.
There is no playback picture, or the playback picture is noisy or contains streaks...	<ul style="list-style-type: none"> • Select channel 3 or 4 on TV to match VCR output channel (3 or 4) (P.6) or select LINE. • Set VCR/TV selector to "VCR." • Adjust TRACKING control in either direction. (P.41) • Try Head Cleaning. (P.41)
Special effects playback, picture may contain some vertical jitter when using a TV with an Automatic Vertical Hold Control...	<ul style="list-style-type: none"> • Set TV's Vertical Hold Control to MANUAL, then adjust.
VCR cannot be controlled...	<ul style="list-style-type: none"> • Make sure VCR LOCK is set to off. (P.36) • Make sure remote is in proper mode. (P.20) • Make sure unit is not in a Timer Record operation.
Remote Control	Correction
VCR cannot be remote controlled...	<ul style="list-style-type: none"> • Aim Remote Control directly at remote sensor on VCR. (P.50) • Avoid any object blocking signal path. • Check remote batteries. (P.4) • Make sure VCR LOCK is set to off. (P.36) • Exposing VCR remote sensor to direct fluorescent or outdoor light may cause signal interference.
ACTION and PROG/VCR+ buttons cannot be used...	<ul style="list-style-type: none"> • Press VCR button for VCR mode. (P.20) • Check remote Batteries. (P.4)
Miscellaneous	Correction
Programs cannot be viewed on TV...	<ul style="list-style-type: none"> • Set VCR/TV selector to "TV." (P.9) • Make sure proper signal source is selected.
Video cassette cannot be inserted...	<ul style="list-style-type: none"> • Insert the cassette with window side up; record tab facing you. • Insure no other tape is inside unit.
Video cassette cannot be removed...	<ul style="list-style-type: none"> • Completely insert Power Plug into AC outlet.
Video cassette ejects when a recording is started or the power is turned off for timer recording...	<ul style="list-style-type: none"> • Make sure cassette record tab is intact. (P.40)
In Stop mode, the motor (CYLINDER) continues to rotate...	<ul style="list-style-type: none"> • To enable Quick play mechanism, the cylinder will rotate for about 5 minutes. This reduces response time from Stop to Play mode and from Play to Rewind Search mode.
The top of the playback picture waves back and forth excessively...	<ul style="list-style-type: none"> • Because VCR playback signal is not as stable as off-the-air TV signal, top of TV screen may be bent or unstable during playback. Slowly turn TV horizontal Hold control to correct. If your TV has no horizontal Hold control or adjusting control is ineffective, contact your nearest TV service center.

If you cannot resolve the problem, please call the Customer Satisfaction Center for product assistance at 201-348-9090.

To locate an authorized servicenter, please call toll free 1-800-211-PANA (7262).

Service Center List

For Product Information, Operating Assistance, Literature Request, Dealer Locations, and all Customer Service inquiries please contact:

1-800-211-PANA (7262), Monday-Friday 9am-9pm Saturday-Sunday 9am-7pm, EST.

Web Site: <http://www.panasonic.com>
 You can purchase parts, accessories or locate your nearest servicer by visiting our Web Site.

Accessory Purchases:

Customer Orders Only 800-332-5368 (Customer Orders Only)
Panasonic Services Company 20421 84th Avenue South, Kent, WA 98032
(6 am to 5 pm Monday - Friday; 6 am to 10:30 am Saturday; PST)
(Visa, MasterCard, Discover Card, American Express, Check)

Factory Servicenters Locations

<p>CALIFORNIA 6550 Katella Avenue Cypress, CA 90630</p> <p>800 Dubuque Avenue S. San Francisco, CA 94080</p> <p>20201 Sherman Way Suite 102 Canoga Park, CA 91306</p> <p>3878 Ruffin Road Suite A San Diego, CA 92123</p> <p>COLORADO 1640 South Abilene Street Suite D Aurora, CO 80012</p> <p>FLORIDA 3700 North 29th Avenue Suite 102 Hollywood, FL 33020</p>	<p>GEORGIA 8655 Roswell Road Suite 100 Atlanta, GA 30350</p> <p>ILLINOIS 9060 Golf Road Niles, IL 60714</p> <p>1703 North Randall Road Elgin, IL 60123 (Pick-up / Drop-off only)</p> <p>MARYLAND 62 Mountain Road Glen Burnie, MD 21061</p> <p>MASSACHUSETTS 60 Glacier Drive Suite G Westwood, MA 02090</p>	<p>MICHIGAN 37048 Van Dyke Avenue Sterling Heights, MI 48312</p> <p>MINNESOTA 7850-12th Avenue South Airport Business Center Bloomington, MN 55425</p> <p>OHIO 2236 Waycross Road Civic Center Plaza Forest Park, OH 45240</p> <p>PENNSYLVANIA 2221 Cabot Blvd. West Suite B Langhorne, PA 19047</p> <p>Chartiers Valley Shopping Center 1025 Washington Pike Bridgeville, PA 15017</p>	<p>TENNESSEE 3800 Ezell Road Suite 806 Nashville, TN 37203</p> <p>TEXAS 7482 Harwin Drive Houston, TX 77036</p> <p>13615 Welch Road Suite 101 Farmers Branch, TX 75244</p> <p>WASHINGTON 20425-84th Avenue South Kent, WA 98032</p> <p>HAWAII 99-859 Iwaiwa Street Aiea, Hawaii 96701 Phone (808)488-1996 Fax (808)486-4369</p>
---	---	---	--

Service in Puerto Rico

Matsushita Electric of Puerto Rico, Inc. Panasonic Sales Company/ Factory Servicer:
 Ave. 65 de Infanteria, Km. 9.5, San Gabriel Industrial Park, Carolina, Puerto Rico 00985
 Phone (787)750-4300 Fax (787)768-2910

As of October '99

Before Requesting Service/
Service Center List

Warranty

Panasonic Consumer Electronics Company,
Division of Matsushita Electric Corporation
of America,
One Panasonic Way
Secaucus, New Jersey 07094

Panasonic Sales Company,
Division of Matsushita Electric of Puerto Rico, Inc.
AVE. 65 de Infantería, Km. 9.5
San Gabriel Industrial Park
Carolina, Puerto Rico 00985

PANASONIC Video Products Limited Warranty

Panasonic Consumer Electronics Company or Panasonic Sales Company (collectively referred to as "the Warrantor") will repair this product with new or refurbished parts, free of charge, in the USA or Puerto Rico, in the event of a defect in materials or workmanship as follows (all time periods commence from the date of the original purchase):

<u>PRODUCT</u>	<u>PARTS</u>	<u>LABOR</u>
CAMCORDER	ONE (1) YEAR, EXCEPT CCD IMAGE SENSOR CCD IMAGE SENSOR - SIX (6) MONTHS	NINETY (90) DAYS NINETY (90) DAYS
VCR	ONE (1) YEAR	NINETY (90) DAYS
A/V MIXER	ONE (1) YEAR	NINETY (90) DAYS
MONITOR-VCR	ONE (1) YEAR, EXCEPT CRT CRT - TWO (2) YEARS	NINETY (90) DAYS CRT - NINETY (90) DAYS CUSTOMER PAYS ALL LABOR CHARGES AFTER 90 DAYS

Monitor-VCR In-home or carry-in Service: 22" (diagonal) CRT / LCD and Larger
Monitor-VCR Carry-in Service: 21" (diagonal) CRT / LCD and smaller

Batteries (if included) - New rechargeable batteries in exchange for defective rechargeable batteries for ten (10) days. Non-rechargeable batteries are not warranted.

Tape (if included) - New video cassette tape in exchange for a defective video cassette tape for five (5) days.

In-home, carry-in or mail-in service, as applicable, in the USA can be obtained during the warranty period by contacting a Panasonic Services Company (PASC) Factory Servicenter listed in the Service Directory. Or call toll free 1-800-211-PANA (7262), to locate an authorized PASC Servicenter. Carry-in or mail-in service in Puerto Rico can be obtained during the warranty period by calling the Panasonic Sales Company telephone number listed in the Servicenter Directory.

This warranty is extended only to the original purchaser. A purchase receipt or other proof of the date of the original purchase is required before warranty service is rendered.

This warranty only covers failures due to defects in materials and workmanship which occur during normal use and does not cover normal maintenance, including, but not limited to, video and audio head cleaning. The warranty does not cover damage which occurs in shipment, or failures which are caused by products not supplied by the warrantor, or failures which result from accident, misuse, abuse, neglect, mishandling, misapplication, alteration, modification, faulty installation, set-up adjustments, improper antenna, inadequate signal pickup, maladjustment of consumer controls, improper operation, power line surge, improper voltage supply, lightning damage, commercial use such as hotel, office, restaurant, or other business or rental use of the product, or service by anyone other than a PASC Factory Servicenter or a PASC authorized Servicenter, or damage that is attributable to acts of God.

LIMITS AND EXCLUSIONS

There are no express warranties except as listed above.

THE WARRANTOR SHALL NOT BE LIABLE FOR INCIDENTAL OR CONSEQUENTIAL DAMAGES (INCLUDING, WITHOUT LIMITATION, DAMAGE TO TAPES) RESULTING FROM THE USE OF THIS PRODUCTS, OR ARISING OUT OF ANY BREACH OF THE WARRANTY. ALL EXPRESS AND IMPLIED WARRANTIES, INCLUDING THE WARRANTIES OF MERCHANTABILITY AND FITNESS FOR PARTICULAR PURPOSE, ARE LIMITED TO THE APPLICABLE WARRANTY PERIOD SET FORTH ABOVE. Some states do not allow the exclusion or limitation of incidental or consequential damages, or limitations on how long an implied warranty lasts, so the above exclusions or limitations may not apply to you.

This warranty gives you specific legal rights and you may also have other rights which vary from state to state.

If a problem with this product develops during or after the warranty period, you may contact your dealer or Servicenter. If the problem is not handled to your satisfaction, then write to the Customer Satisfaction Center at the Panasonic Consumer Electronics Company address above.

SERVICE CALLS WHICH DO NOT INVOLVE DEFECTIVE MATERIALS OR WORKMANSHIP AS DETERMINED BY THE WARRANTOR, IN ITS SOLE DISCRETION, ARE NOT COVERED. COSTS OF SUCH SERVICE CALLS ARE THE RESPONSIBILITY OF THE PURCHASER.

warvid 10/20/97

Para ajustar el idioma, canal y reloj

1 Encienda el televisor y la videograbadora.

Presione POWER.

- Si se utiliza un cable de conexión AV, sitúe el TV en la posición Video en lugar de en la posición canal. (Véase el punto a, en la página 4).

2

Visualización de SELECCIÓN DE IDIOMA.

Esta visualización aparece sólo cuando realice la configuración por primera vez.

Seleccione el idioma.

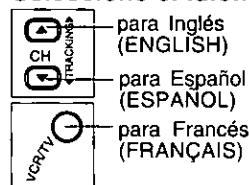

Si se utiliza la conexión b) (véase la página 4), sintonice en el canal de salida de VCR.

Si la imagen tiene oscilaciones o ruido cuando el equipo está situado en VCR OUTPUT CH3, cambie a CH4 pulsando ACTION dos veces.

Luego, sintonice el TV en el CH4.

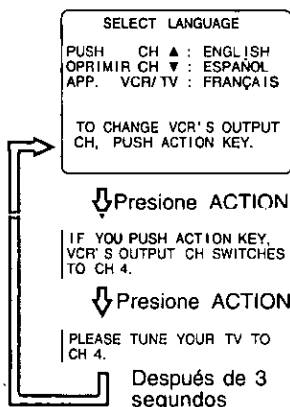

- Sintonice siempre el TV a este canal para monitorizar la video grabadora.
- Si utilizó la conexión del conector audio/video, sintonice el TV a su entrada de video.
- Si se ajusta el idioma equivocado, realice los pasos de "Reajuste de todas las funciones de memoria de la video grabadora" en la página 40.

3

Seleccione la conexión.

- 1) Presione ▲▼ para seleccionar.
- 2) Presione ► para ajustar.

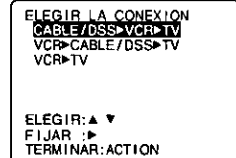

- Si ud. ha elegido CABLE/ DSS ► VCR ► TV, continúe al paso 4 y sólo el canal de salida del cable será memorizado. Si no, vaya al paso 6.

4

Seleccione la caja de TV por cable o su receptor al canal de salida.

- 1) Presione ▲▼ para seleccionar.
- 2) Presione ► para fijar.

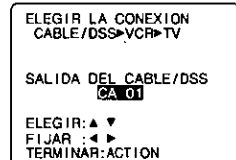

- Si es necesario, consulte su manual de la caja de TV por cable.
- Si esta usando los terminales de audio/ video para su conexión para la caja de TV por cable, ajuste "SALIDA DE VIDEO".

5 Encienda la caja de TV por cable y fije la caja de TV por cable al canal PBS de su zona.

6

FIJACION AUTO. (CA/RELOJ)

CONECTE EL CABLE DE LA ANTENA Y SI ESTA USANDO UNA CAJA DE TV POR CABLE SINTONICE AL CANAL PBS DE SU LOCAL LUEGO...

POR FAVOR OPRIMIR CH UP

Comience el ajuste automático de canales y el ajuste automático del reloj.

Presione CH ▲.

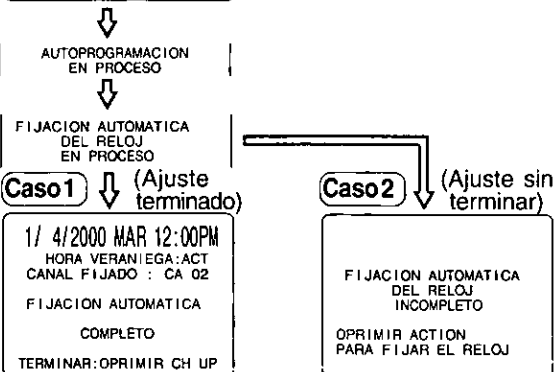

Caso 2 El ajuste del reloj es incompleto.

Ajuste el reloj manualmente.

- 1) Presione ACTION.
- 2) Presione ▲▼ para seleccionar el mes.
- 3) Presione ► para ajustar.
 - De la misma manera, ajuste el día, el año, la hora y la hora de ahorro de energía (VERANO).
 - Para hacer correcciones, presione repetidamente ◀► para moverse hasta el error, luego corríjalo.
- 4) Presione ACTION. (El reloj se activa.)
 - Para salir de este modo, pulse la tecla ACTION nuevamente.

Ajustar de nuevo el reloj

1 Presione ACTION para exhiba el menú.

2

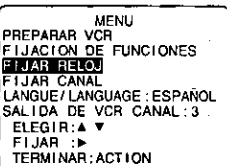

Presione ▲▼ para seleccionar "FIJAR RELOJ" y luego presione ►.

3

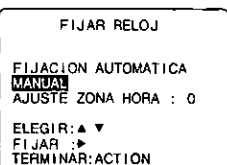

Presione ▲▼ para seleccionar "MANUAL" y luego presione ►.

4

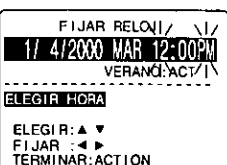

Presione ▲▼ y ◀► para seleccionar y ajustar la hora y la fecha.

5 Presione ACTION dos veces para que el reloj comience a funcionar y salir desde este modo.

Operaciones básicas para la reproducción

1 Inserte un casete.

- La videograbadora se enciende automáticamente.

2 Presione PLAY.

- O, si el casete no tuviera la lengüeta de grabación (véase la página 40), se inicia la reproducción automática.
- Para encontrar una escena en particular
Búsqueda hacia adelante ---> Presione FF.
Búsqueda hacia atrás ---> Presione REW.
- Para ver una imagen fija (congelada) --->
Presione PAUSE/SLOW.
- Para ver imágenes cuadro a cuadro --->
Presione PAUSE/SLOW en el modo de imagen fija.
- Para ver en cámara lenta ---> Mantenga pulsado el botón PAUSE/SLOW en el modo de imagen fija.
- Para parar ---> Presione STOP.
- Para rebobinar la cinta ---> Presione REW.
- Para hacer avanzar la cinta rápidamente --->
Presione FF
- Para expulsar la cinta ---> Presione STOP/EJECT en el videograbadora.

Programación fácil para la grabación con temporizador

1 Exhiba FIJAR PROGRAMACION.

Presione PROG/VCR+.

2



Exhiba "TEMPORIZADOR".

- 1) Presione ▲▼ para seleccionar.
- 2) Presione ► para exhibir.

- Si ya existe un programa en la memoria, presione ▲▼ y ► para seleccionar un número de programa sin usar.

3

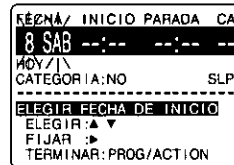

Ajuste la fecha de grabación.

- 1) Presione ▲▼ para seleccionar.
- 2) Presione ► o ◀ para ajustar.

- 1-31 = Grabación única
- DIARIO = a la misma hora de lunes a viernes
- SEMANA = a la misma hora una vez a la semana

Ejemplo
Fecha de hoy — 7 — 8 — 9 31 — 1 — 2 6 — DIARIO
▲ / ▼ Orden para elegir
SEMANTAL (SAB) SEMANTAL (LUN) SEMANTAL (DOM)

Repita el paso 3 para ajustar: hora de comienzo, hora de parada, canal (o LINEA para una fuente exterior), categoría*, velocidad (SP, LP, SLP).

* Categoría NO, DEPORTE, CINE, COMEDIA, MUSICA, DRAMA

4



Haga las anotaciones necesarias.

- Si no fueran necesarias, vaya al paso 5.

- 1) Presione ▲ para hacerlas.
- 2) Presione ▲▼ para seleccionar.
- 3) Presione ◀ para ajustar.
- 4) Presione PROG/VCR+ (o ACTION) para salir.

5

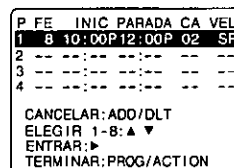

Termine el programa.

- 1) Presione PROG/VCR+ (o ACTION).

Para introducir más programas, presione ▲▼ y ► para seleccionar y ajustar el número de programa en blanco. Luego repita los pasos 3 y 4.

- 2) Presione PROG/VCR+ (o ACTION) para salir.

6



Grabación con temporizador.

Presione POWER para apagar.

- Si la fuente de la grabación es una caja de TV por cable, asegúrese de que la caja de TV por cable esté encendida y esté sintonizada al canal que desea grabar.

Operaciones básicas para la grabación

1

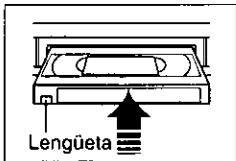

Inserte un casete.

- La videograbadora se enciende automáticamente.

2 Seleccione el canal.

Presione CH ▲ / ▼ o las teclas numéricas correspondiente.

3 Seleccione la velocidad de grabación.

Presione SPEED.

- SP = Reproducción estándar,
- LP = Larga duración,
- SLP = Superlarga duración.

4 Comience la grabación.

Presione REC.

- Presione PAUSE/SLOW para hacer una pausa en la grabación en progreso.

- Para parar ---> Presione STOP.

Grabación de un toque

Presione REC repetidamente para ajustar la hora de grabación (30 min - 4 horas).

- La videograbadora termina la grabación a una hora programada.

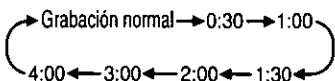

Location of Controls

Remote control Buttons

EJECT
See page 8.

POWER
See page 6.

VCR mode
See page 20.

VCR/ TV
See page 9.

PLAY
See page 8.
SELECT UP
See page 7.

REWIND/ SEARCH
See page 8.
SET
See page 7.

ACTION
See page 38.

NUMBERED KEYS
See page 9.

COUNTER RESET
See page 29.

PAUSE/ SLOW
See page 8.

COMMERCIAL ADVANCE
See Page 23.

SAP/ Hi-Fi
See page 31.

VOLUME UP/ DOWN
See page 20.

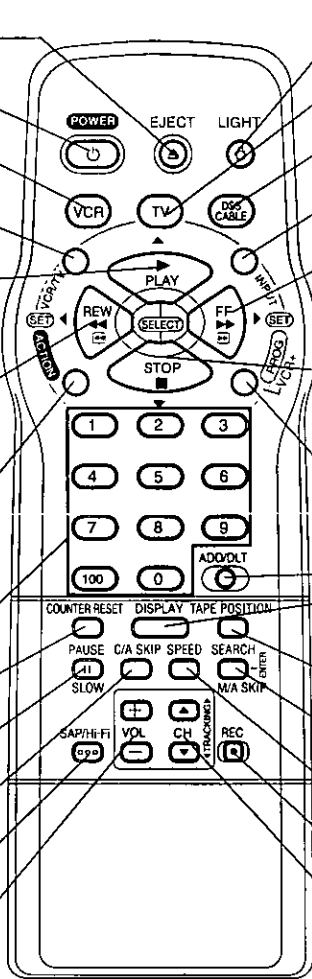

LIGHT
See page 50.

TV mode
See page 20.

DSS/ CABLE mode
See page 20.

INPUT
See page 11.

FAST FORWARD/ SEARCH
See page 8.
SET
See page 7.

STOP
See page 8.
SELECT DOWN
See page 7.

PROGRAM/ VCR+
See pages 12, 13, 19, 35.

ADD/ DELETE
See page 39.

DISPLAY
See page 42.

TAPE POSITION
See page 36.

SEARCH/ MOVIE ADVANCE
See pages 25-29.

SPEED
See page 9.

RECORD
See page 9.

CHANNEL UP/ DOWN
See page 9.
TRACKING/ V-LOCK
See page 41.

Light Tower Universal Remote Control

Light button: When the LIGHT button is pressed, the buttons which can be activated in the selected mode will light and the selected mode button (TV/VCR or CABLE DSS) will flash for 5 seconds. If no buttons are pressed within 5 seconds, the light will turn off in order to conserve battery power. Also while holding down the buttons, the selected mode button will flash so you will be able to see, in the dark, which mode has been selected.

EJECT button: When EJECT is pressed, the tape is ejected from Cassette Compartment. If EJECT is pressed during recording, the VCR will not respond to the command.

Front View of the VCR

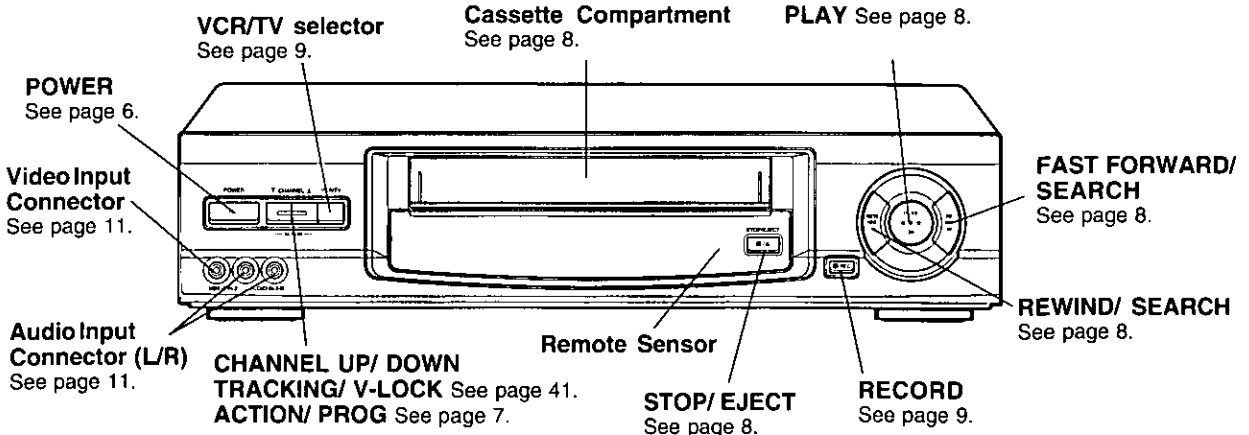

Multi Function Display

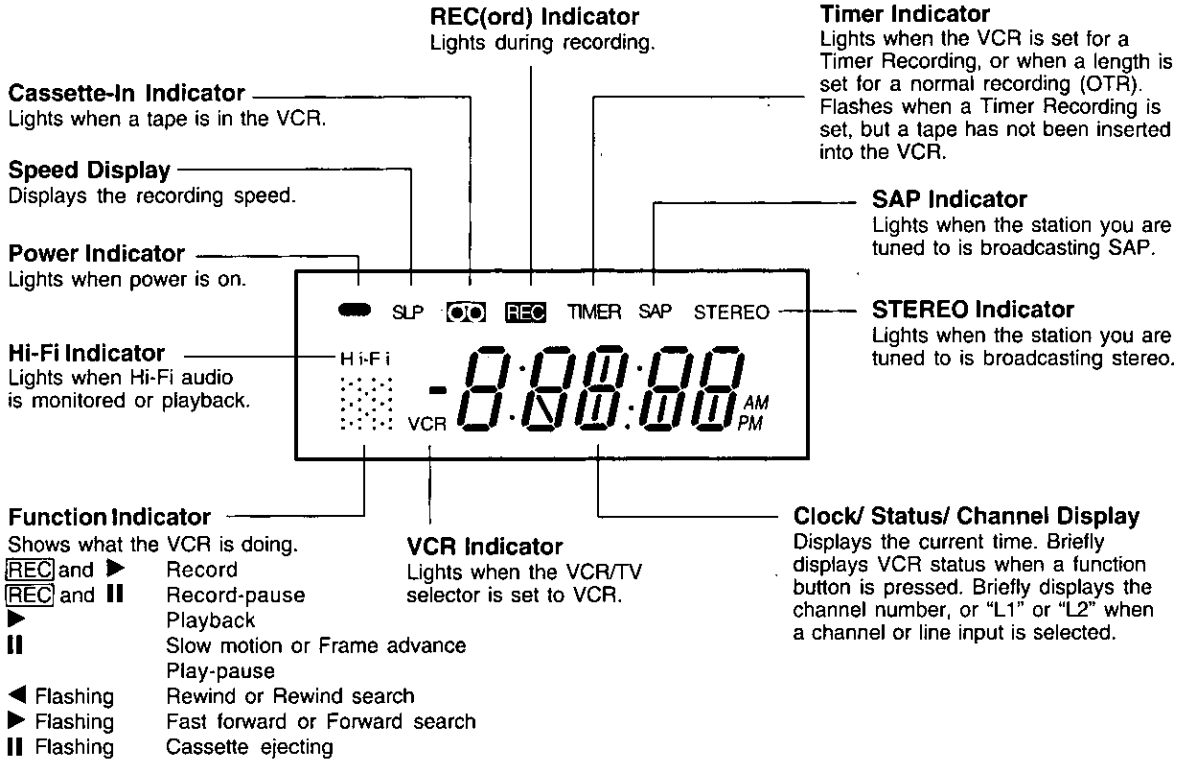

Rear View of the VCR

AC Power Plug

While plugged into an AC outlet, the VCR consumes 3.3 W of electrical power in off condition.

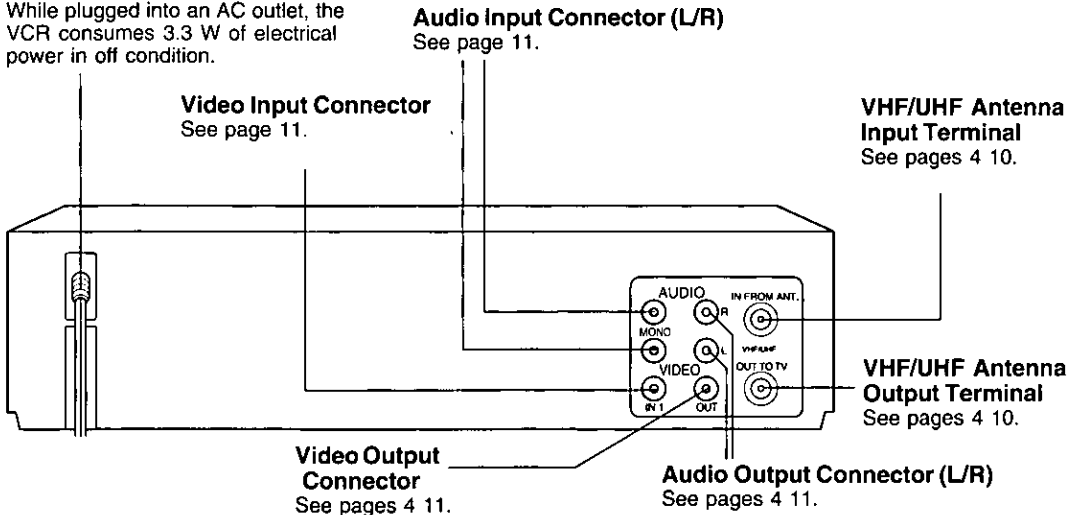

Quick Use Guide

1 Make all connections (page 4).

Connect VCR and TV with AV Cable (not supplied) or RF Coaxial Cable (supplied) as shown below. To use your TV as a VCR monitor, set the VIDEO/TV selector on the TV (Monitor/Receiver) to "VIDEO." Use the L Audio OUT jack for proper sound reproduction when connecting to a monaural TV.

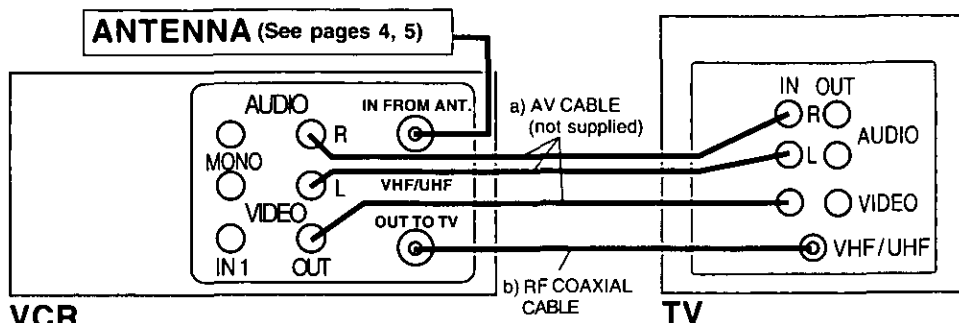

- Notes**
- 1) While connection b) (above) is sufficient, connection a) offers better sound and picture (especially with this model, you can enjoy Hi-Fi STEREO sound).
 - 2) For both connections a) and b) proceed as follows:
 - To use VCR : VCR Power on, set TV to VIDEO.
 - To watch TV : VCR Power off, select channel on.
 - 3) When using connection b) (see page 4), tune to VCR's output channel.
 - 4) Set VCR Output to channel 3 or 4 (not an active station). (See page 6.)

Playback a Tape

2 Play your Tape.

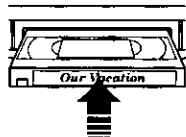

Insert a tape

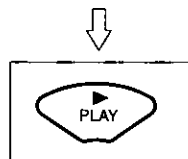

Press PLAY
(Starts playback)
• Or, if tape has no record tab, auto playback begins.

Record on a Tape

2 Do "One Time VCR Setup" on page 6.

In order for the VCR to properly interface with your equipment, some setup is necessary.

3 Record on a Tape.

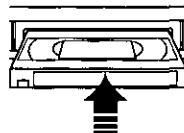

Insert a tape with Record Tab

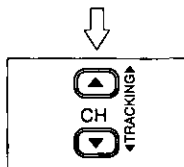

Press CH Up/Down.
(Select Channel)

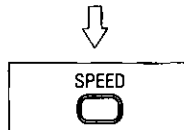

Press SPEED.
(Change speed)

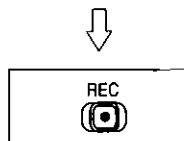

Press REC.
(Starts Recording)